

## Fuel Strainer Parts for Cessna Aircraft

McFarlane can replace your fuel system parts with high quality McFarlane manufactured parts. Now offering fuel bowls, fuel bowl washers, fuel bowl nuts, standpipes, plungers, stainless steel washers for your plunger, and the fuel strainer seal kit. Buy any of these components separately or as convenient kits.

- Improved safety
- More reliable
- Longer life
- Less money

### Maintenance Tip:

*Cleaning the Fuel Screen - The fuel screen is removed by removing the standpipe. The rubber tipped plunger must be unseated before the standpipe is loosened. Failure to lift the plunger off of its standpipe seat can damage the plunger. Pull the strainer drain knob as if you were draining the fuel bowl. Block or clamp the knob in this position. Insert a smooth round tool such as a screw driver or punch in the standpipe cross-hole and un-screw the standpipe.*

### Fuel Bowl MC0756008-1

- Computer machined (not die cast).
- Gold anodized for additional corrosion resistance.
- This bowl is engineered to last!



### Fuel Strainer Standpipe MC0756011-1

- Stainless steel
- Costs less
- No more corrosion pits
- No more stripped threads
- The last one you will buy!



### Fuel Strainer Plunger MC0756010-11

- Special electro polished shaft for longer o-ring life
- McFarlane's Vulcanize bonded blue Viton® rubber tip outlasts the original in any fuel.



### Fuel Strainer Seal Kit FS-KT-1

Only McFarlane has approval to replace the old less fuel resistant o-rings with the latest fuel-proof fluoro-carbon o-ring.



## Fuel Strainer Kits for Cessna Aircraft

Save time and money with convenient kits!  
*See eligibility on the following page.*

Qty	Part Number	Description	Index
<b>FS-KT-1 Fuel Strainer Seal Kit</b>			
1	MC0756009-8	Gasket	5
1	MCM83248/1-010	O-ring	9
1	MCM83248/1-111	O-ring	10
1	MCM83248/1-138	O-ring	11
<b>FS-KT-2 Fuel Bowl Kit</b>			
1	FS-KT-1	Fuel Strainer Seal Kit	
1	MC0756008-1	Fuel Bowl	4
1	MC0756015-1	Washer	8
1	MCS1573-3	Nut	13
<b>FS-KT-3 Fuel Strainer Rebuild Kit</b>			
1	FS-KT-2	Fuel Bowl Kit	
1	0756012-1	Spring	3
1	MC0756010-11	Plunger	6
1	MC0756011-1	Standpipe	7
2	MCS145027A7-032	Washer	12
<b>FS-KT-4 Fuel Strainer Kit</b>			
1	FS-KT-3	Fuel Strainer Kit	
1	0756005-2	Top Assembly	1
1	0756009-1	Filter	2
<b>FS-KT-5 Fuel Strainer and Cable Kit</b>			
1	FS-KT-4	Fuel Strainer Kit	
1	S1517-7	Strainer Drain Cable	14

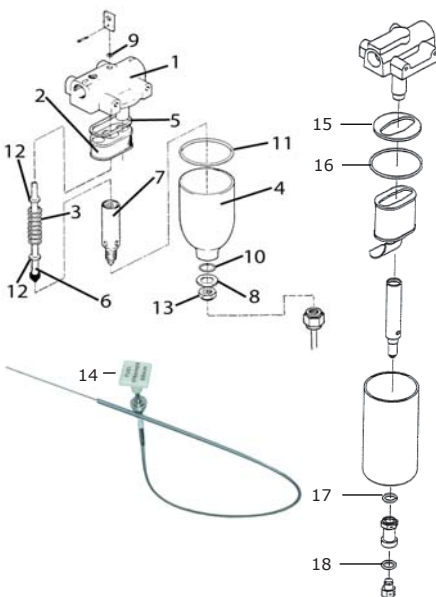

Qty	Part Number	Description	Index
<b>FS-KT-6 Fuel Strainer Kit</b>			
1	0756005-2	Top Assembly	1
1	0756009-7	Filter	2
1	FS-KT-3	Fuel Strainer Rebuild Kit	
<b>FS-KT-7 Fuel Strainer and Cable Kit</b>			
1	FS-KT-6	Fuel Strainer Kit	
1	S1517-7	Strainer Drain Cable	14
<b>FS-KT-8 Fuel Strainer and Cable Kit</b>			
1	FS-KT-4	Fuel Strainer Kit	
1	S1239-16	Strainer Drain Cable	14
<b>FS-KT-9 Fuel Strainer Seal Kit</b>			
1	0756041-1	Gasket	15
1	M83248/1-011	O-Ring	18
1	M83248/1-111	O-Ring	17
1	M83248/1-138	O-Ring	16
<b>FS-KT-10 Fuel Strainer Seal Kit</b>			
1	0756041-1	Gasket	15
1	M83248/1-010	O-Ring	9
1	M83248/1-111	O-Ring	17
1	M83248/1-138	O-Ring	16
<b>FS-KT-11 Fuel Strainer Seal Kit</b>			
1	0756041-1	Gasket	15
1	M83248/1-111	O-Ring	17
1	M83248/1-138	O-Ring	16

## Cessna 177RG and F177RG Fuel Reservoir Drain Plunger

- All metal, one piece design eliminates the flimsy C-clip.
- McFarlane's Vulcanize bonded blue Viton® rubber tip outlasts the original in any fuel.
- Convenient kits available containing the plunger and O-Rings, part number FDV-KT-1.



SAVE!

**New!**

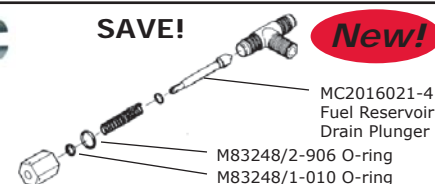

## Eligibility for Fuel Strainer Parts and Kits for Cessna Aircraft

Cessna Models	Serial Numbers	MC0756008-1	MC0756010-11	MC0756011-1	FS-KT-1	FS-KT-2	FS-KT-3	FS-KT-4	FS-KT-5	FS-KT-6	FS-KT-7	FS-KT-8	FS-KT-9	FS-KT-10	FS-KT-11
150 E*,F,G,H,J,K,L,M	15061153 thru 15079405 and 649	x	x	x	x	x	x	x	x						
A150K,L,M	A1500001 thru A1500734 and 15064970	x	x	x	x	x	x	x	x						
F150F,G,H,J,K,L,M	F150-0001 thru F15001428	x	x		x	x									
FA150K,L,M	FA1500001 thru FA1500336	x	x		x	x									
152	15279406 thru 15286033	x	x	x	x	x	x	x	x						
A152	A1520735 thru A1521049 and A1500433, 681	x	x	x	x	x	x	x	x						
F152	15201429 thru 15201980	x	x		x	x									
FA152	FA1520337 thru FA1520425	x	x		x	x									
172F*,G,H	17252534 thru 17256512 and 638	x	x	x	x	x	x	x					x		
172I,K,L,M,N,P,Q	172556513 thru 17276654 and 17256493	x	x	x	x	x	x	x	x						
172R,S	17280001 thru 17299999, 172S8001 thru 172S9999													x	
172RG	172RG0001 thru 172RG0890 and 691	x	x	x	x	x	x	x	x						
172RG	172RG0891 thru 172RG1191														
P172D	P17257120 thru P17257188	x		x	x	x	x	x	x						
F172F*,G,H,K,L,M,N,P	F172-0140 thru F17202254	x	x		x	x									
FR172E,F,G,H,J,K	FR17200001 thru FR17200675	x	x		x	x									
R172K	R1722000 thru R1723454	x	x		x	x									
177, 177A,B	17700001 thru 17702752 and 661	x	x	x	x	x	x	x	x						
177RG	177RG0001 thru 177RG1366	x	x	x	x	x	x	x							
F177RG	F177RG0001 thru F177RG0177			x											
180H*,J,K	18051497 thru 18053203	x	x	x	x	x	x	x	x						
182H*,J,K,L,M,N,P,Q,R	18256040 thru 18268586 and 675, 18255845	x	x	x	x	x	x	x	x						
182S,T	18280001 and On														x
F182P,Q	F18200001 thru F18200169	x	x		x	x									
FR182	FR18200001 thru FR18200070	x	x		x	x									
R182	R18200001 thru R18202041	x	x	x	x	x	x	x	x						
T182	18267716 thru 18268541 and 18267302	x	x	x	x	x	x	x	x						
T182T	T18208001 thru T18299999														x
TR182	R18200001 thru R18202041	x	x	x	x	x	x	x	x						
185D*,E	185-0844 thru 185-1149	x	x	x	x	x	x				x	x			
A185E*,F	185-1150 thru 18504448	x	x	x	x	x	x				x	x			
188,188A,B	188-0001 thru 18802348 and 653	x	x	x	x	x	x								
A188,A188A,B* (w/ fuselage tanks)	188-0001 thru 18802348, 18800833T thru 18802348T and 653, 678T	x	x	x	x	x	x				x	x			
A188,A188A,B* (w/ wing tanks)	188-0001 thru 18802348, 18800833T thru 18802348T and 653, 678T	x	x	x	x	x	x				x				
A188B* (w/ fuselage tank)	18802349 thru 18802745	x	x	x	x	x	x				x	x			
A188B* (w/ wing tanks)	18802349 thru 18803973, 18802349T thru 18803973T	x	x	x	x	x	x				x				
T188C	T18803325T thru T18803974T and T18802839T, 3307T, 3308T	x	x	x	x	x	x				x				
206H,T206H	20608001 thru 20699999, T20608001 thru T20699999														x
P206,P206A,B,C,D,E	P206-0001 thru P20600647	x	x	x	x	x	x				x	x			
TP206A,B,C,D,E	P206-0191 thru P20600647 and P206-0001	x	x	x	x	x	x				x	x			
U206, U206A,B,C,D,E,F*	U206-0276 thru U20602199	x	x	x	x	x	x				x	x			
U206F*,G*	U20602200 thru U20606846 and 676	x	x	x	x	x	x				x	x			
U206G*	U20606847 thru U20607020														x
TU206A,B,C,D,E,F*	U206-0487 thru U20602199	x	x	x	x	x	x				x	x			
TU206F*,G*	U20602200 thru U20606846 and 676	x	x	x	x	x	x				x	x			
TU206G*	U20606847 thru U20607020														x
207,207A,T207,T207A	20700001 thru 20700788	x	x	x	x	x	x				x	x			
210E,F,G	21058511 thru 21058936	x	x	x	x	x	x				x				
210H,J,K,L,M,N*	21058937 thru 21064535	x	x	x	x	x	x				x	x			
210N*	21064536 thru 21064897	x		x	x										
T210F,G	T210-0001 thru T210-0307	x	x	x	x	x	x				x				
T210H,J,K,L,M,N*	T210-0308 thru T210-0454, 21059200 thru 21064535 and 21058140	x	x	x	x	x	x				x	x			
T210N*	21064536 thru 21064897	x		x	x										
P210N*	P21000001 thru P21000760	x	x	x	x	x	x				x	x			
P210N*	P21000761 thru P21000834	x		x	x	x									
337, 337A,B,C,D,E,F	337-0001 thru 33701462	x	x		x	x									
337G,H (std range)	33701463 thru 33701950 and 33701449	x	x	x	x	x	x				x				
337G,H (long range)	33701463 thru 33701950 and 33701449	x	x		x	x									
F337E,F,G,H	F3370001 thru F3379999	x	x		x	x									
FT337E,F, FT337GP, FT337HP	FT3370001 thru FT3370055, FP3370001 thru FP3379999	x	x		x	x									
T337B,C,D,E,F*	337-0526 thru 33701351 and 337-0001	x	x		x	x									
T337F*	33701352 thru 33701398	x			x	x									
T337H (std range)	33701816 thru 33701950	x			x	x									
T337H (long range)	33701816 thru 33701950	x		x	x	x									
T337G, P337H	P3370001 thru P3370356 and 677		x	x											

\* Partial model eligibility

## Fuel Bowl Gaskets for Cessna and Piper Aircraft

Part Number	Replaces OEM P/N	Eligible Models
CAB3-11-1	Cessna P/N CAB3-11-1	300 series (except 303),400 series (except 402C,406,425,441)
CA751-871	Piper P/N 751-871	PA-24-400,PA-28-235,PA-32-260,-300,PA-30,PA-39
Manufactured by PMA Products, Inc.		

