

FAA-PMA Approved

**Airforms Complete FAA-PMA Product Line**

Airforms is located in the heart of the Alaskan aviation scene. Their products are developed from real world needs of experienced Alaskan bush pilots and operators. All Airforms parts are manufactured using state-of-the-art CAD/CAM technology and CNC equipment combined with exemplary craftsmanship to provide the highest quality product.

**Stock in the lower  
48 states for fast,  
economical delivery!!**

**Alaska Bush Tough!**

**Nose Baggage Compartment Cargo Door  
Up Latch for Cessna 207 Aircraft**  
No more holding up the door while loading!  
P/N AF1213922-1



- Improved strength
- Nickel plated for corrosion resistance
- Precision fit - drop in direct replacement
- Approved for all 207 models

**Door Latch for Piper Navajo PA-31 Aircraft**  
Will not deform after extended use!  
P/N AF472-004



- Precision wire EDM machined from solid stainless steel
- Precision fit - drop in direct replacement
- Improved wear resistance
- Approved for all PA-31-310, 325 and 350 models with and without extended cargo door.

**Axles for Cessna Aircraft**  
Don't lose an airplane because of  
a broken aluminum axle!

**Now also in  
Titanium!**

**Steel axle P/N AF1441003-1**

- Weighs only 2.28 lbs
- Save hundreds of \$\$

**Titanium axle P/N AF1441003-1T**

- Reduces weight by 2 lbs per A/C vs. steel axles
- Will not rust - perfect for saltwater environments



Steel axle  
P/N AF1441003-1



Titanium axle  
P/N AF1441003-1T

Model
170, 170A,B
180, 180A-H
182, 182A-S
T182, R182, TR182
185, 185A-E, A185E-F
206, U206, U206A-G and TU206A-G
P206, P206A-E, TP206A-E
206H, T206H
305A,B,C,D,E,F
All serial numbers of each model listed are approved.

**High Strength Parts for Helio H-295 Courier Aircraft**

Parts are manufactured from high strength material and machined from a single billet  
Stronger than original welded assemblies!

**Axle**  
P/N AF250-040-495

- Cad plated for increased durability
- Precision fit - drop in direct replacement
- Accommodates wheel-ski installation



**Stabilator Bracket**  
Left Hand P/N AF391-022-401-2  
Right Hand P/N AF391-022-401-3

- Cad plated and primed for increased durability
- Sold as a match-machined set
- Mounting holes match drill at installation to ensure exact fit

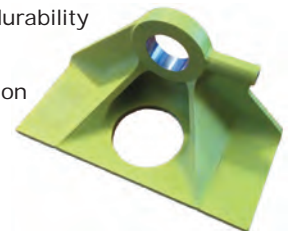

**Complete Engine Baffle Kits**

Keep your engine cool with new baffle kits!  
Airforms is the premier manufacturer of FAA-PMA replacement baffle kits  
for Cessna, Piper and the Beechcraft Baron.

- 6061-T6 aluminum with black high temperature fiberglass reinforced silicone seals pre-installed (orange or blue seals available as special order for an extra charge)
- Bare aluminum or gray powder coat finish
- Individually interchangeable with factory baffles

**Many Improvements:**

- Stainless steel brackets where needed
- Hard rivet construction
- 1/2" back plates to secure seals
- Improved fit

**Notes:**

- If aftermarket components (starter, alternator, exhaust, engine mod, etc) have been installed it is the installer's responsibility to adjust baffles to fit.
- Mounting hardware is not included (nuts, bolts, screws, Tinnerman clips, etc).

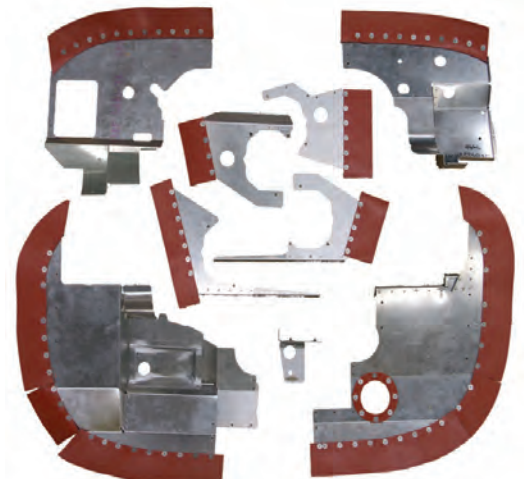

See eligibility and figures on the following pages

Parts manufactured by  
Airforms



Eligibility for Airforms Engine Baffle Kits

Table with columns: Aircraft Model, Serial Number, Bare Aluminum P/N, Powder Coat P/N, Figure. Rows include manufacturers like Beechcraft, Cessna, Grumman, Mooney, and Piper.

Notes:
1 Partial model eligibility
2 To determine the part number required see oil cooler configuration with applicable figure.
3 Baffle seals are available in black only.
4 P/N AF0550165-2 and AF0550165-6 are available in black only.
5 Baffle kits and components have received Alternative Method Of Compliance (AMOC) from the FAA for AD 93-23-13. Mandatory 50 hour inspection is no longer required.

See figures on the following pages

FAA-PMA Approved

**Figure 1**

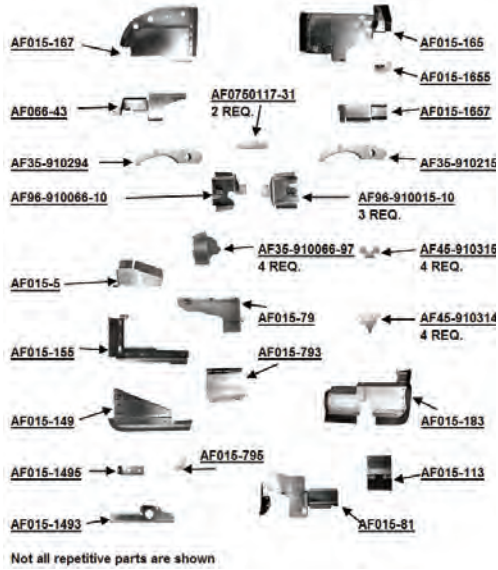

**Figure 2**

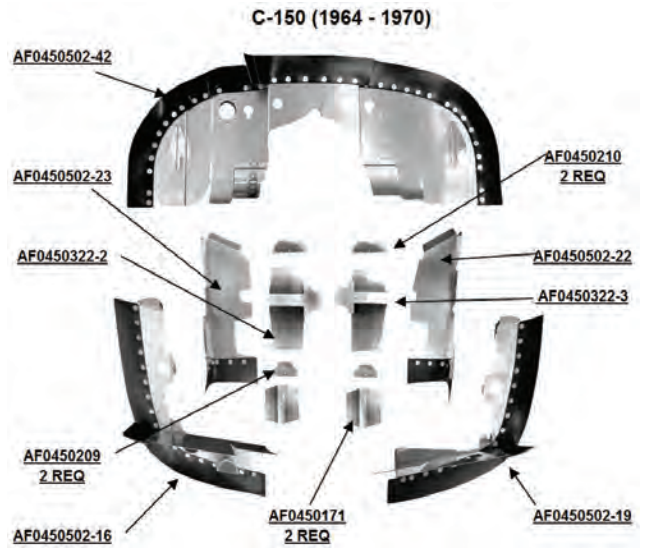

**Figure 3**

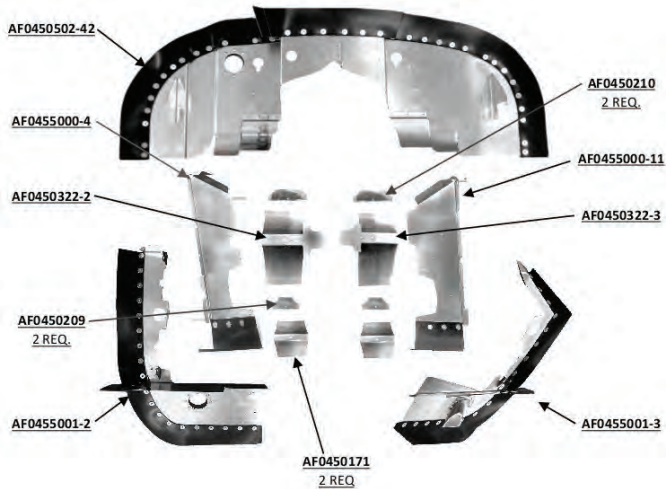

**Figure 4**

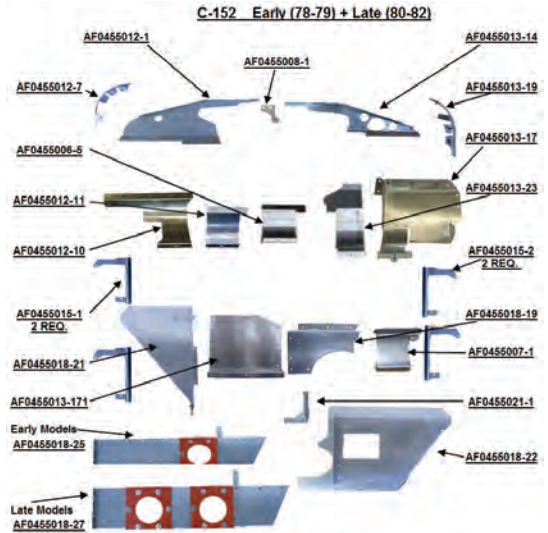

**Figure 5**

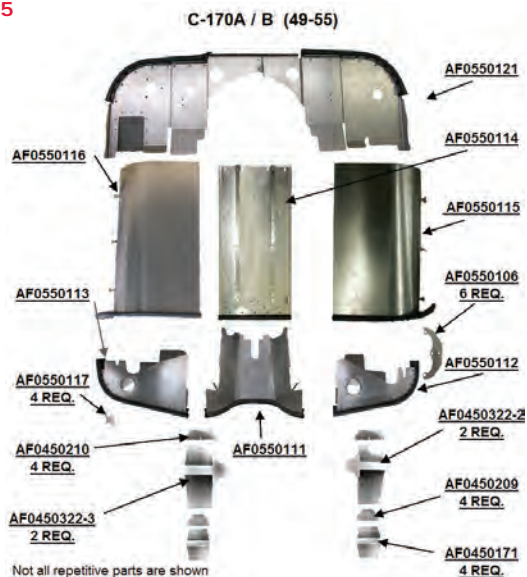

**Figure 6**

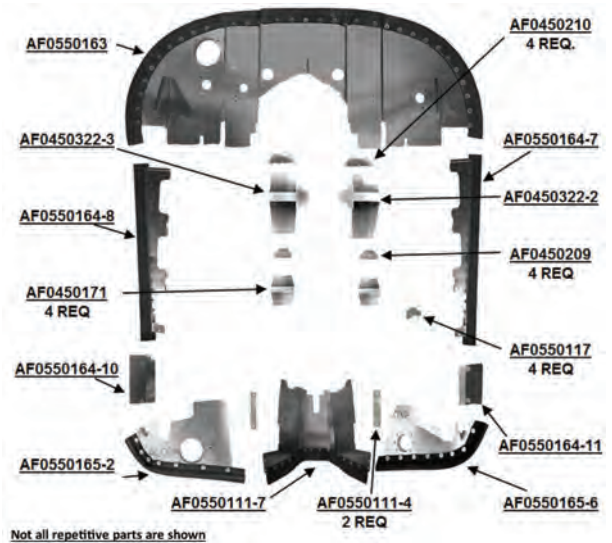



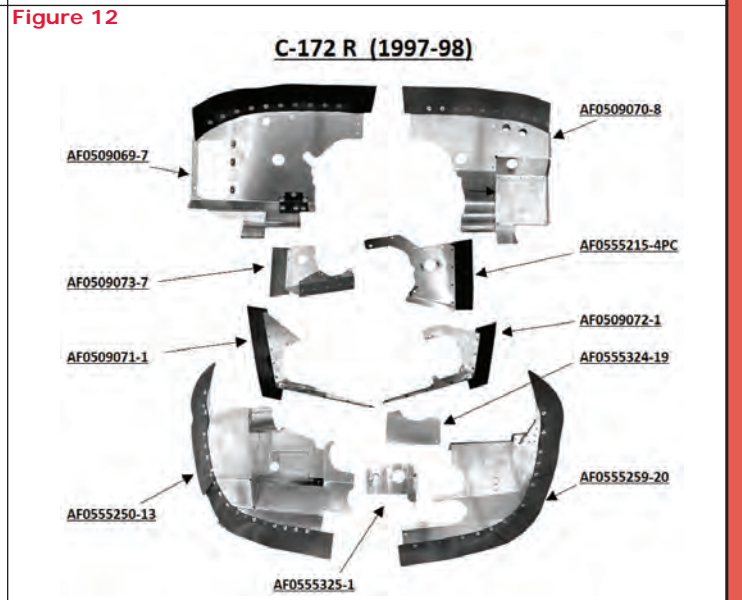
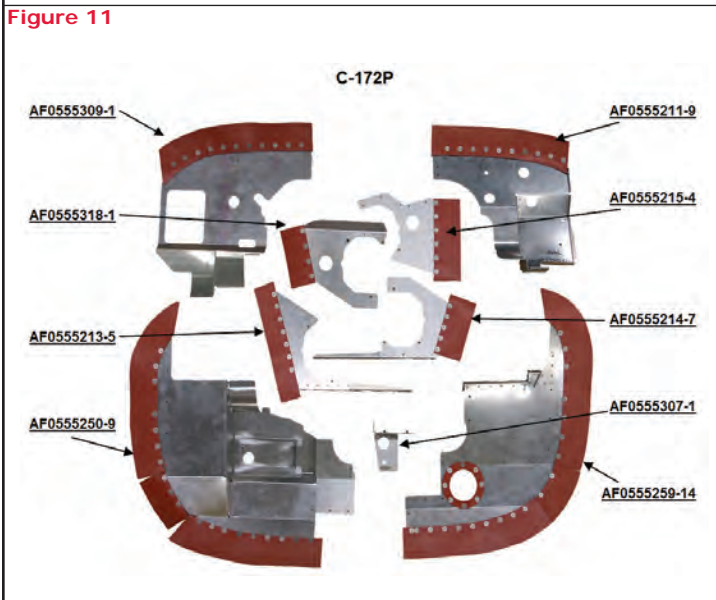
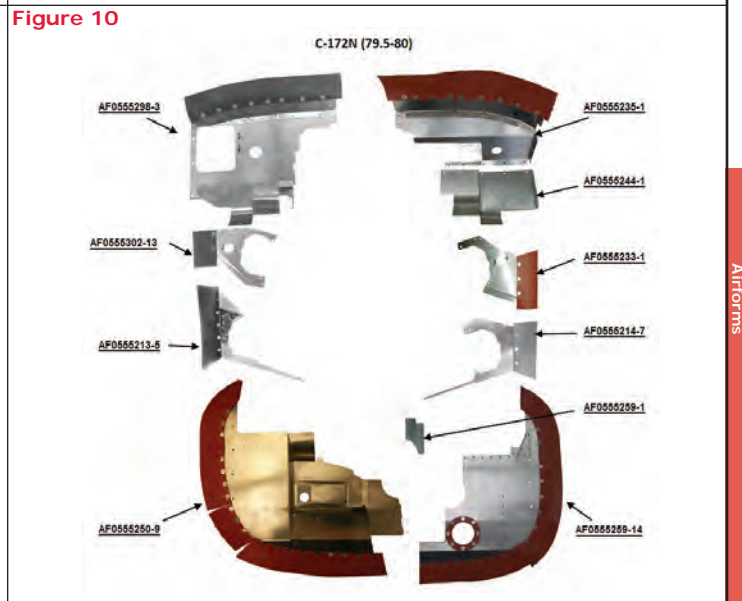
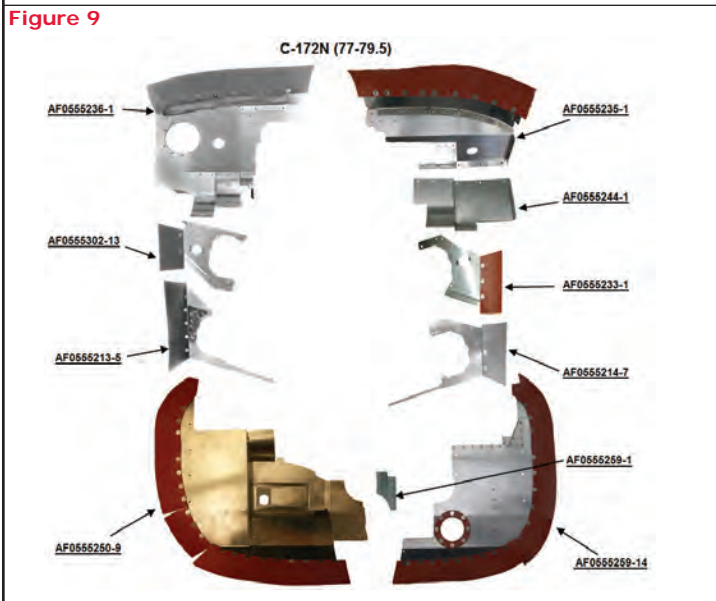
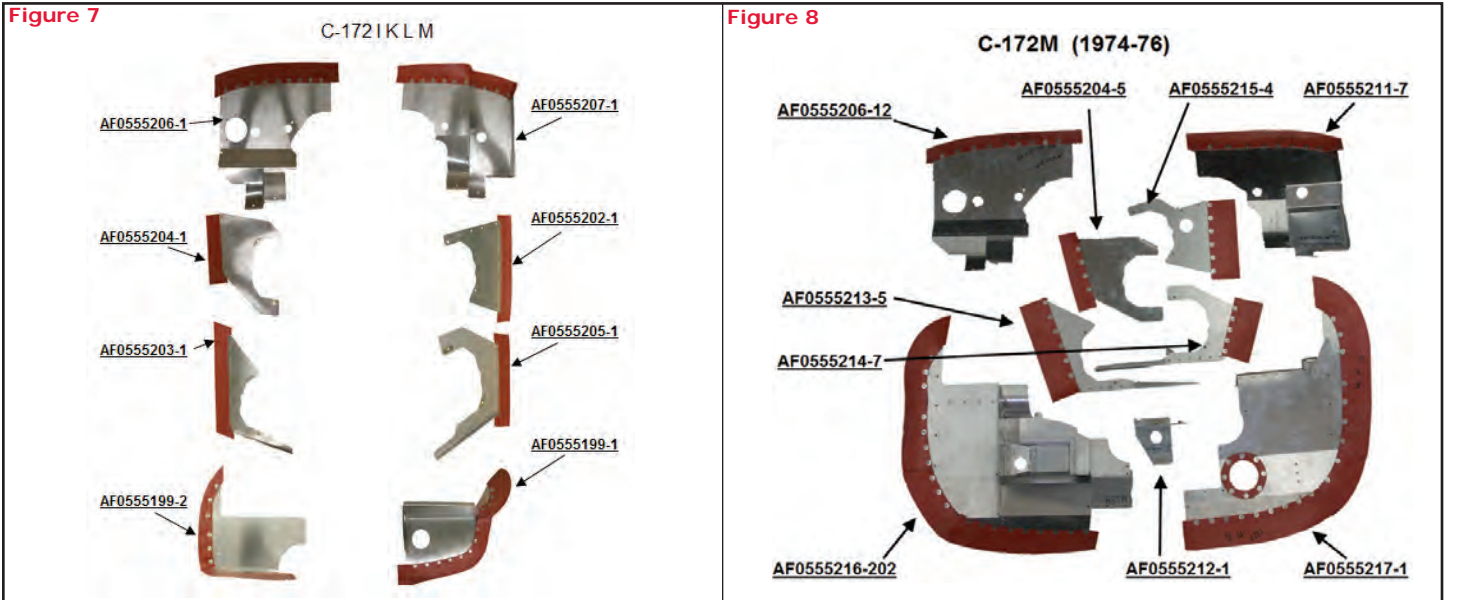

Figure 13

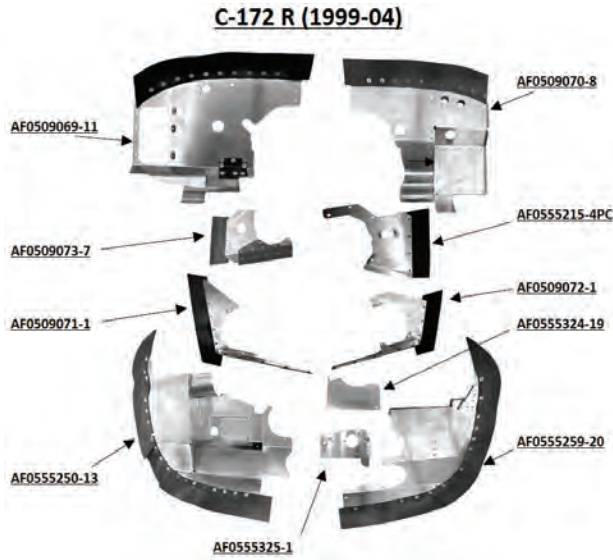

Figure 14

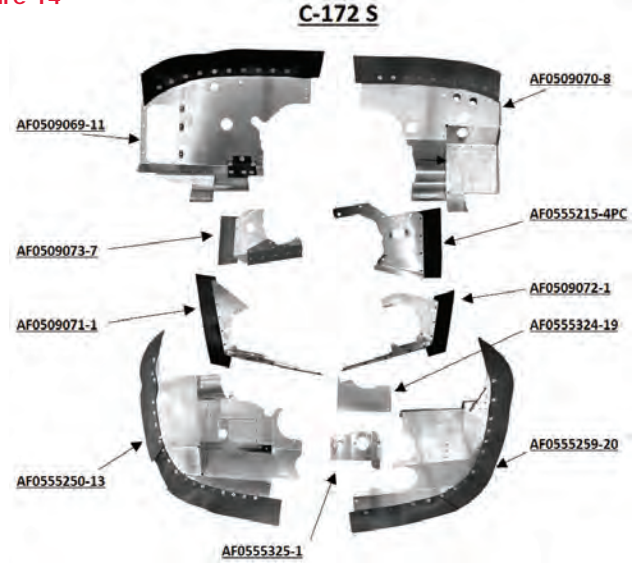

Figure 15

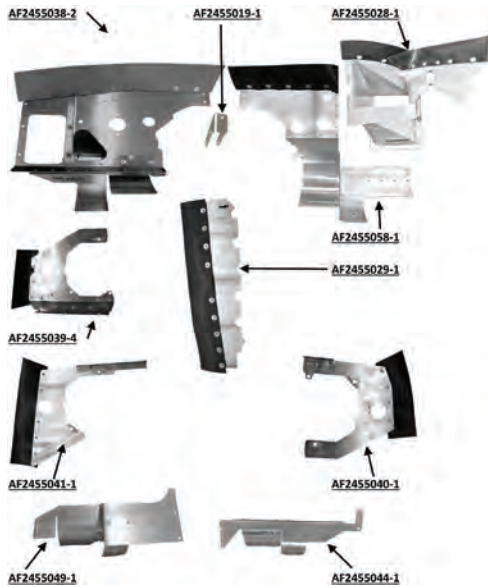

Figure 16

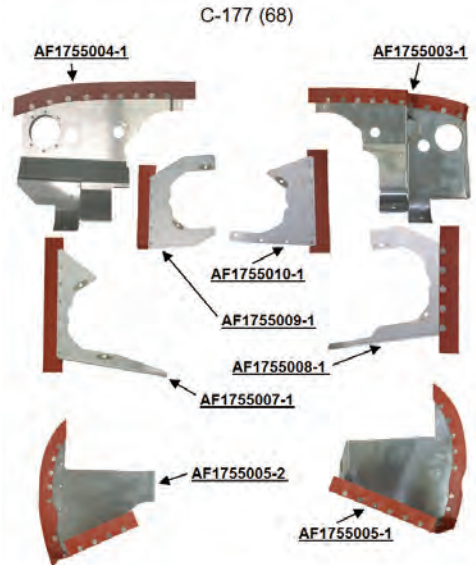

Figure 17

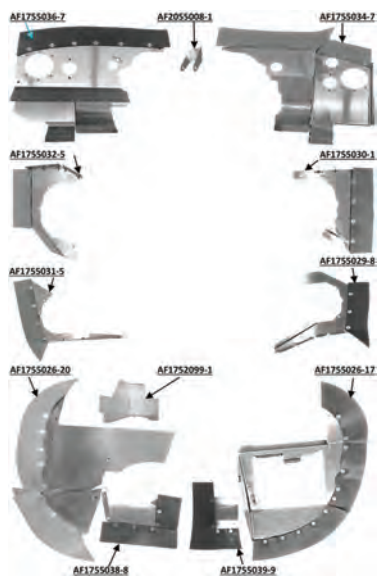

Figure 18

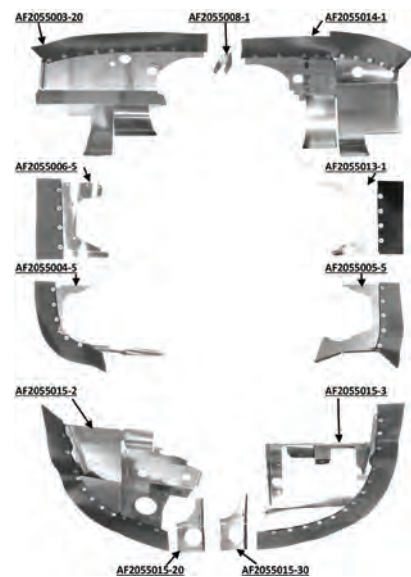



Figure 19

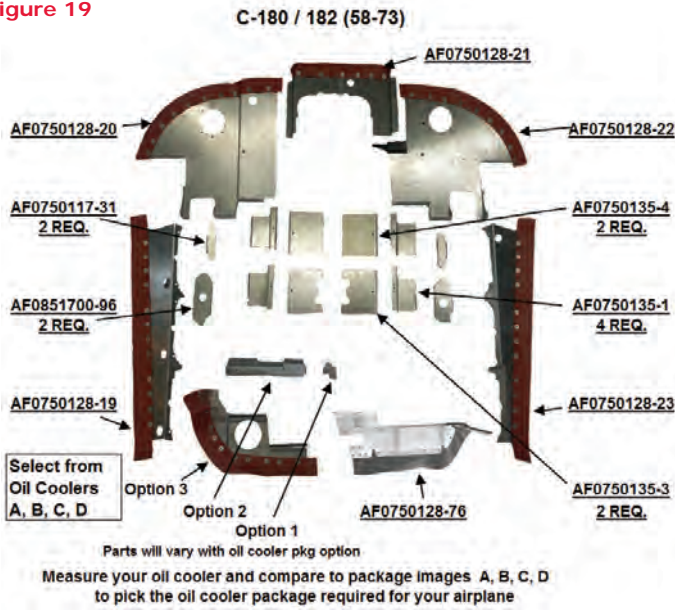
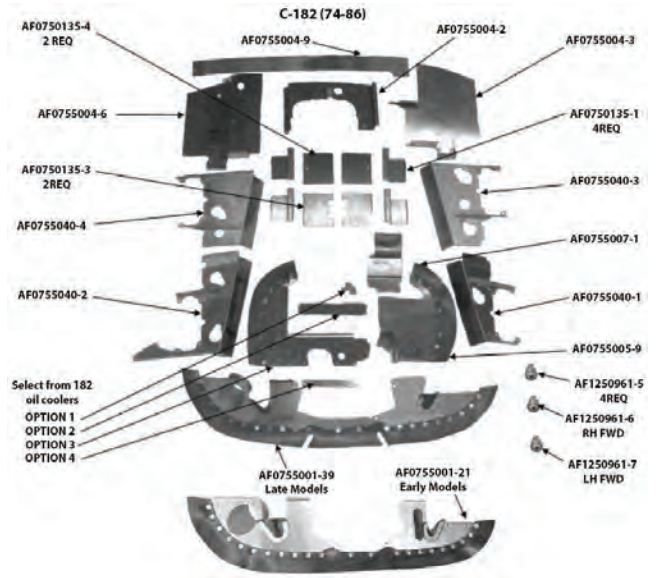
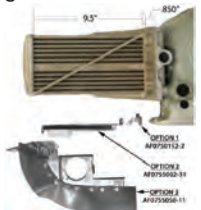

Figure 20



Package A



Package B

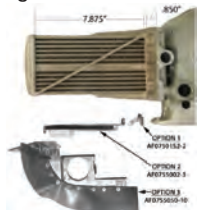

Package C

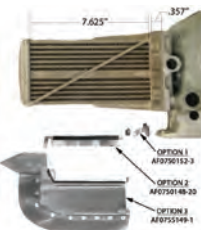

Package D

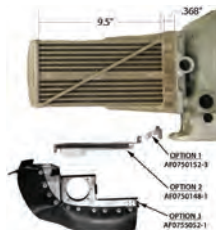

Package G

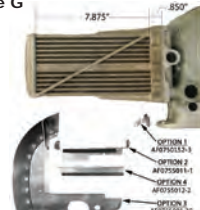

Package H

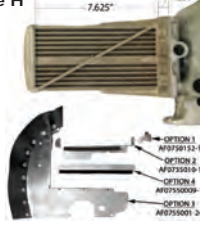
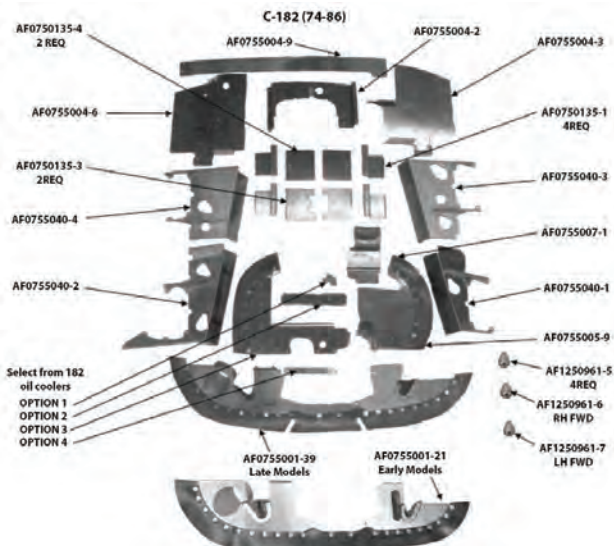
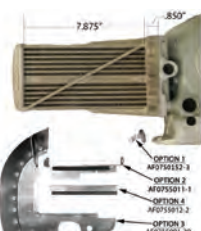

Figure 21



Package G



Package H

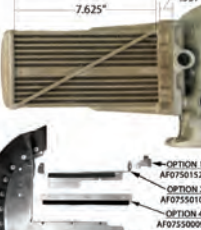

FAA-PMA Approved

**Figure 22**

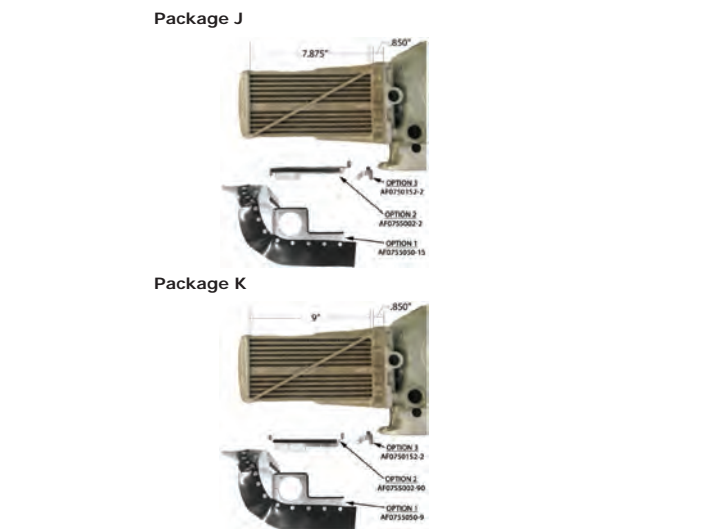
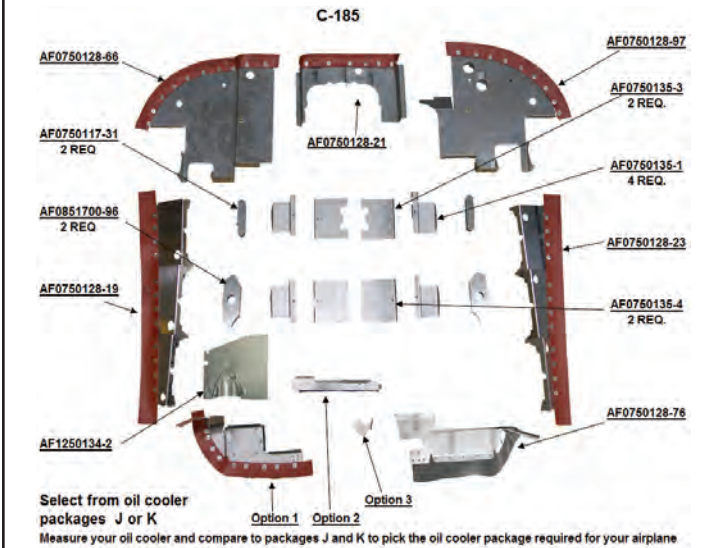

**Figure 23**

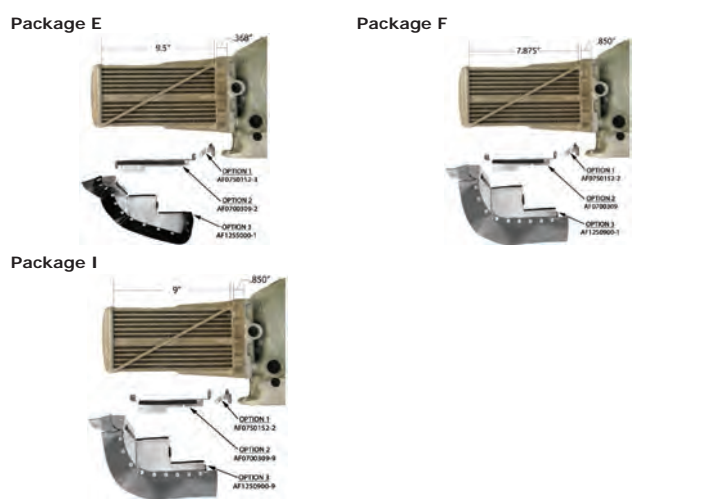
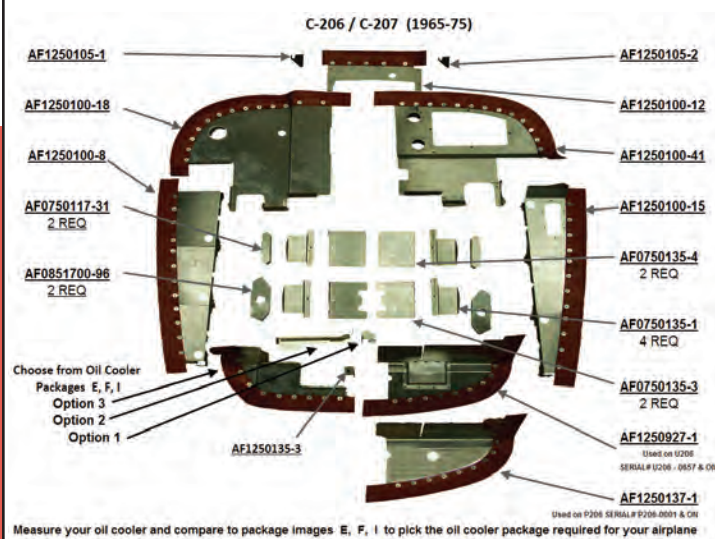

**Figure 24**

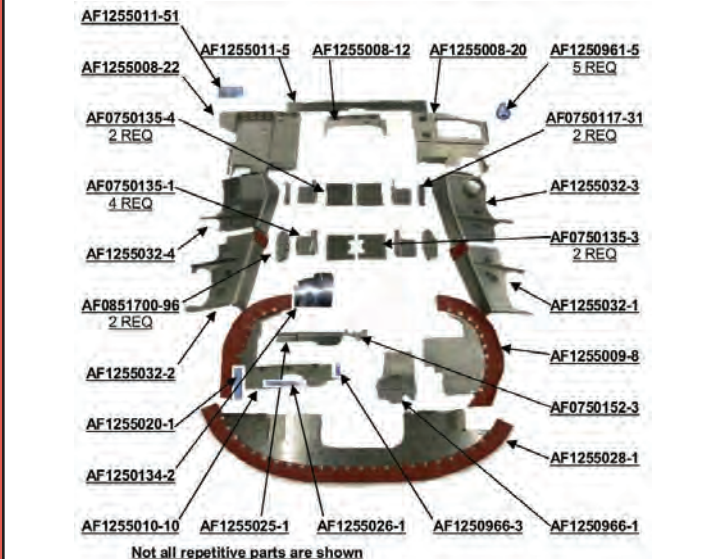

**Figure 25**

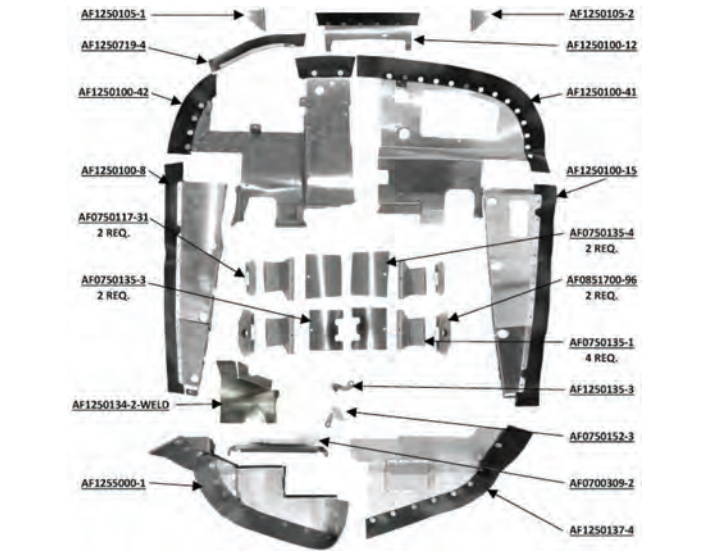

Parts manufactured by Airforms



Figure 26

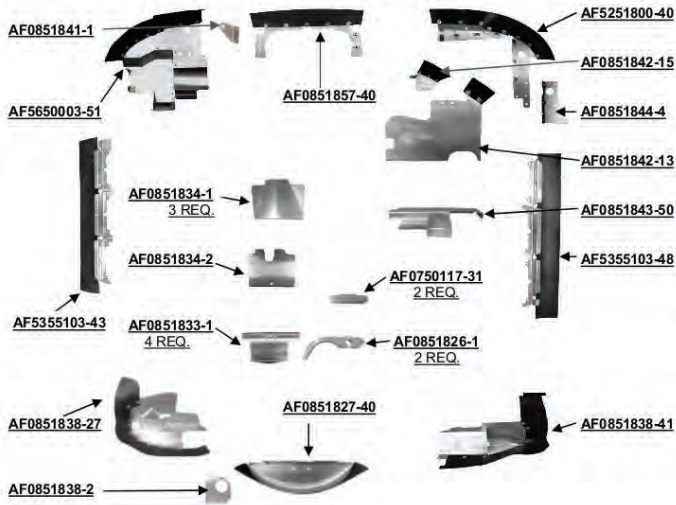

Figure 27

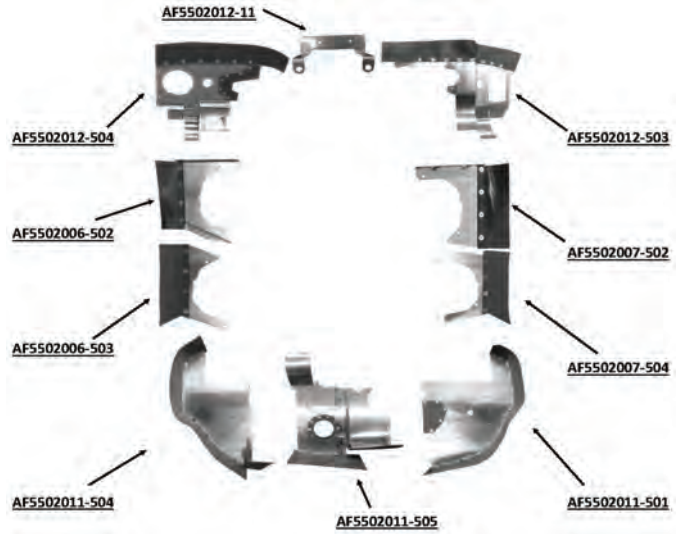

Figure 28

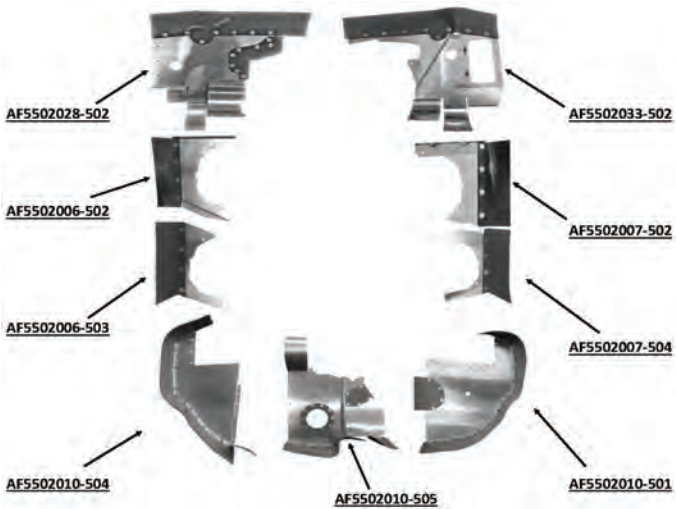

Figure 29

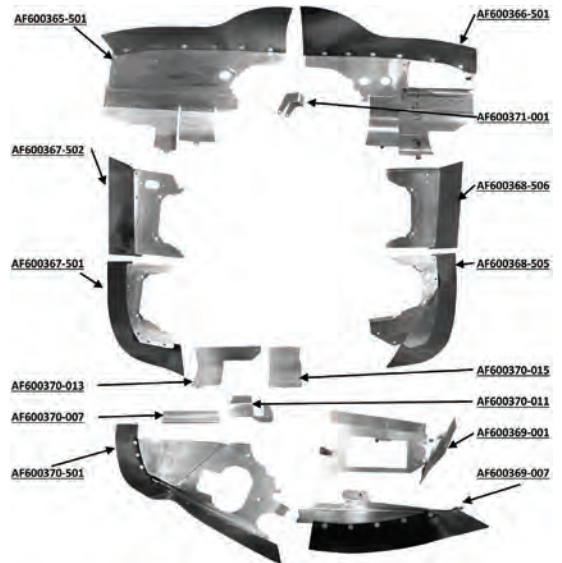

Figure 30

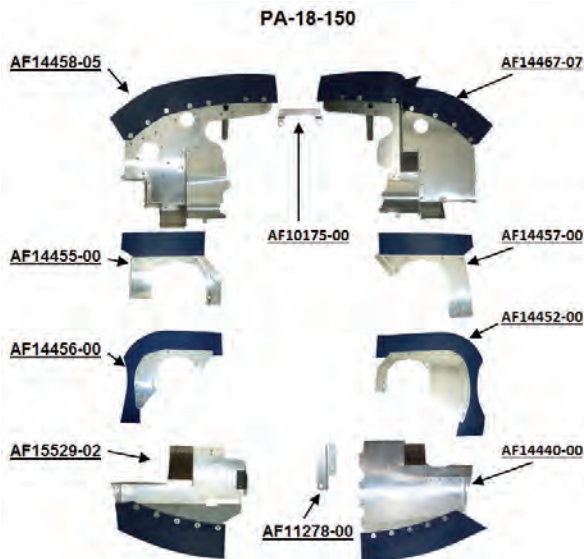
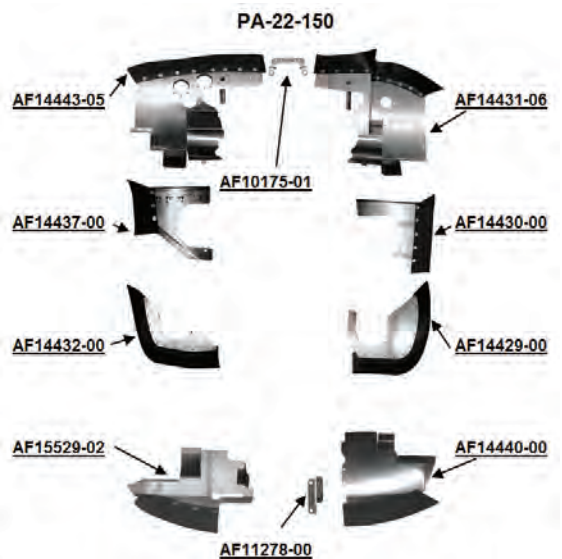
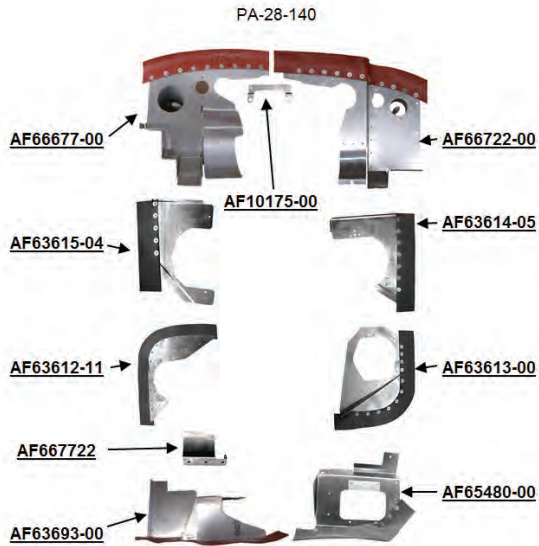

Figure 31

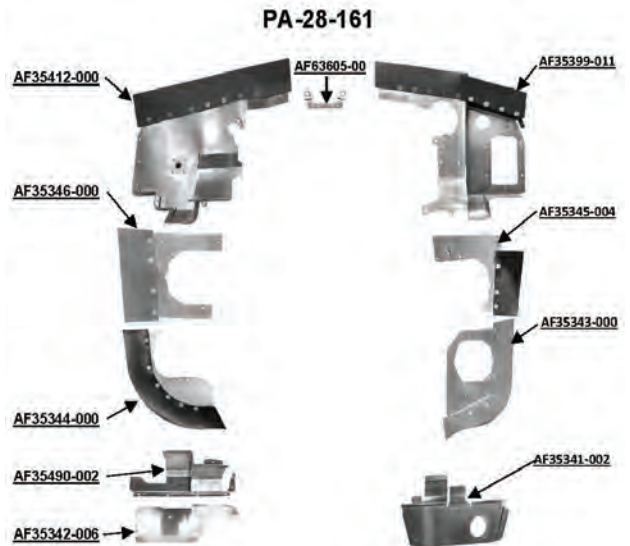



**Figure 32**



**Figure 33**



**Figure 34**

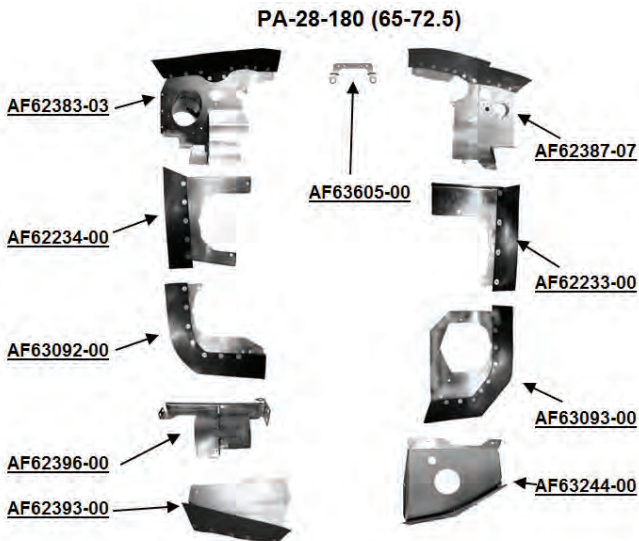

**Figure 35**

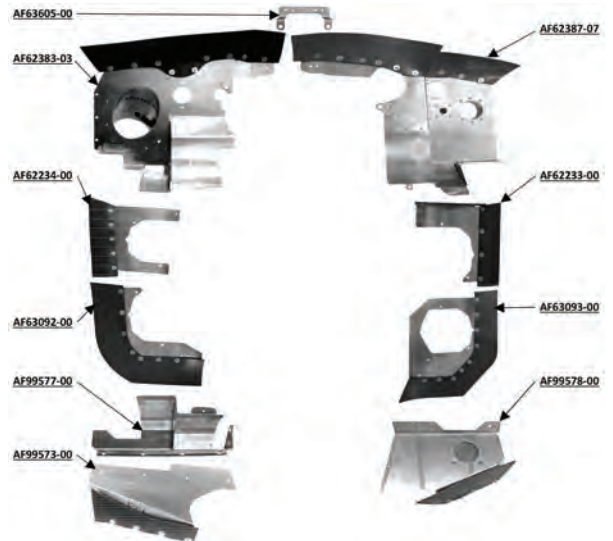

**Figure 36**

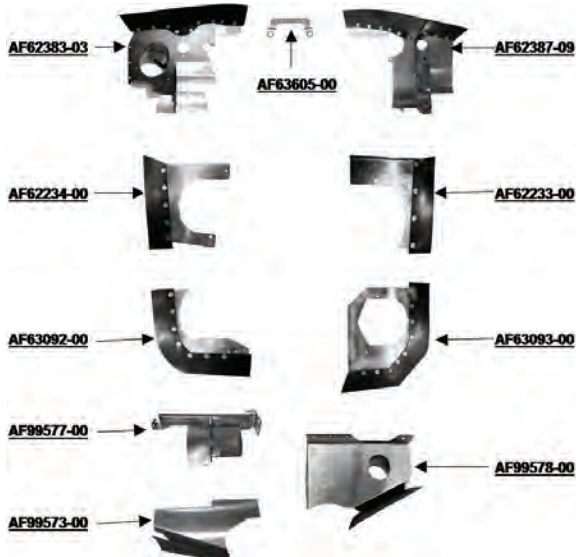

**Figure 37**

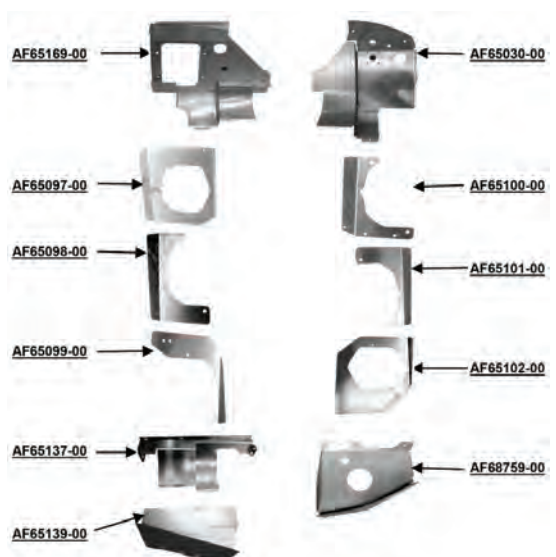

Figure 38

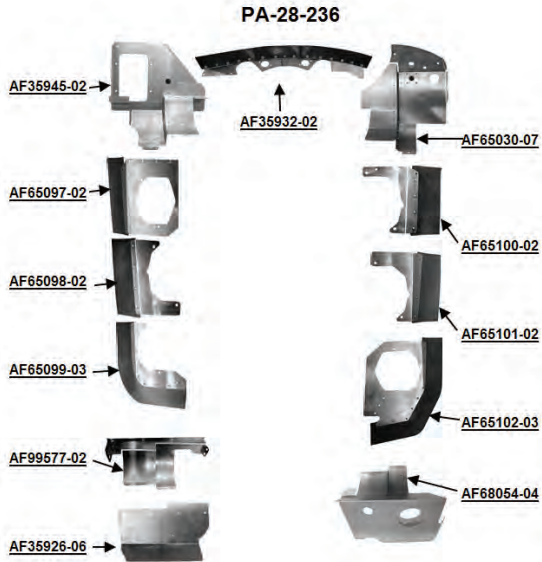

Figure 39

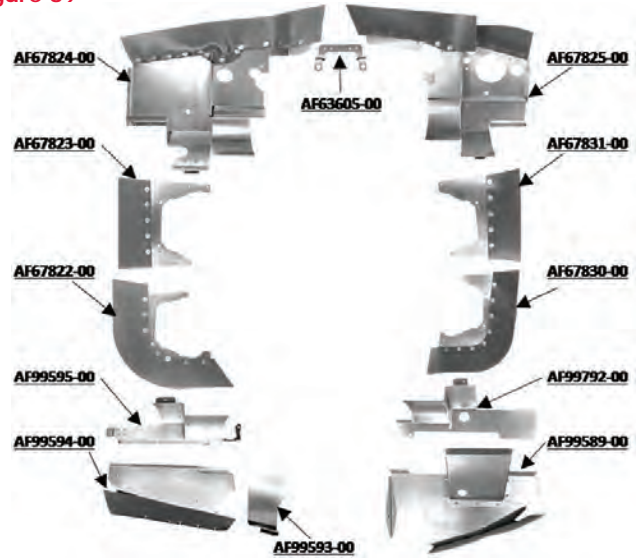

Figure 40

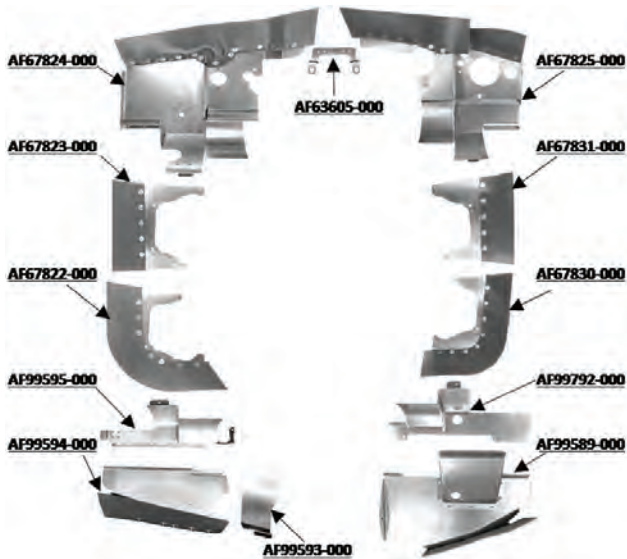

Figure 41

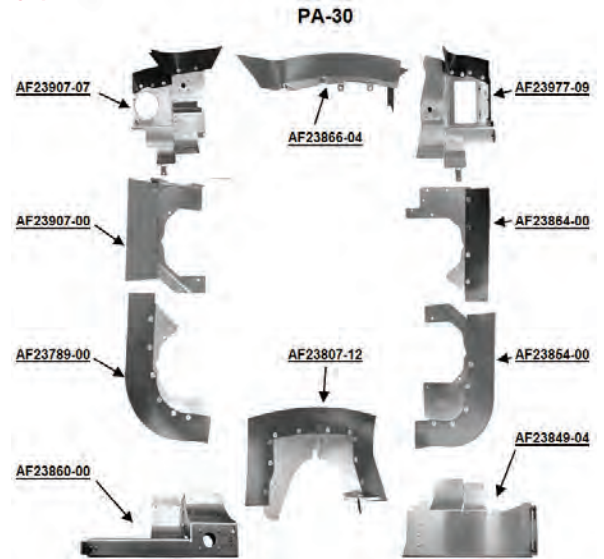

Figure 42

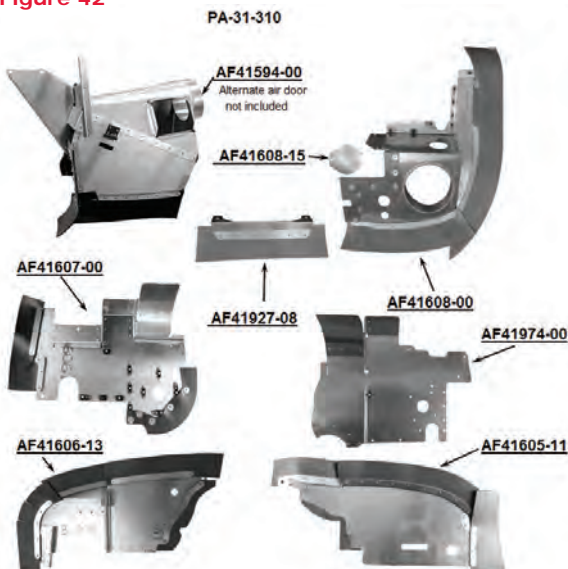
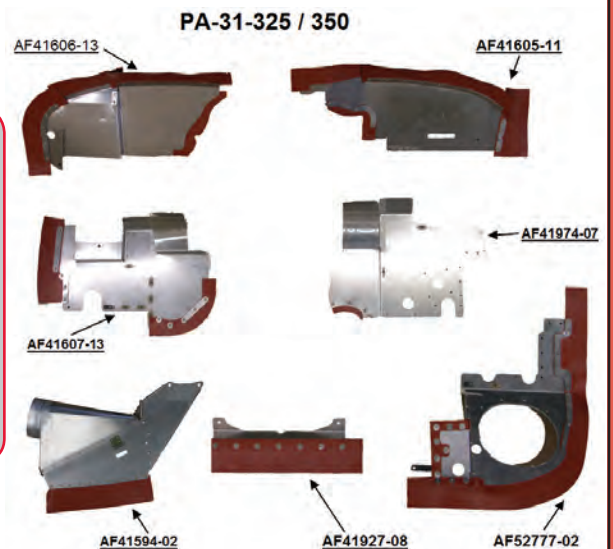

Figure 43



*Baffle kits and components for models PA-31 (PA-31-310), PA-31-325 and PA-31-350 have received Alternative Method Of Compliance (AMOC) from the FAA for AD 93-23-13. Mandatory 50 hour inspection is no longer required.*



FAA-PMA Approved

**Figure 44**

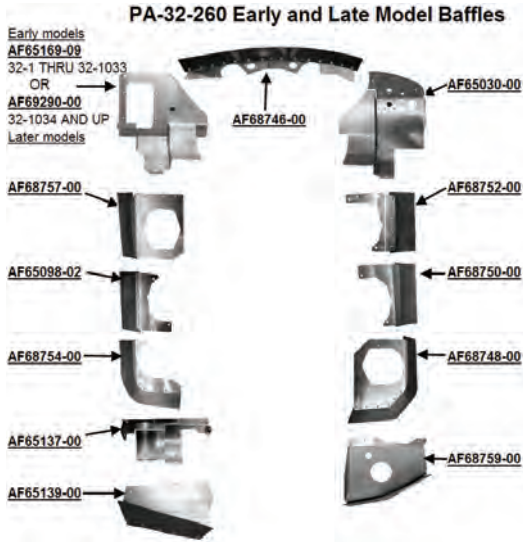

**Figure 45**

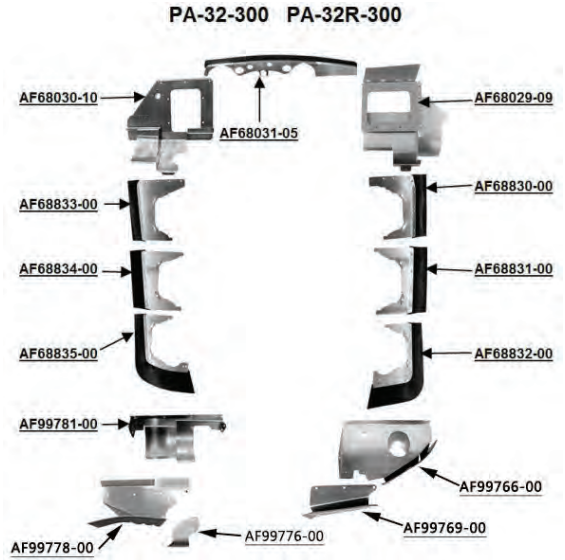

**Figure 46**

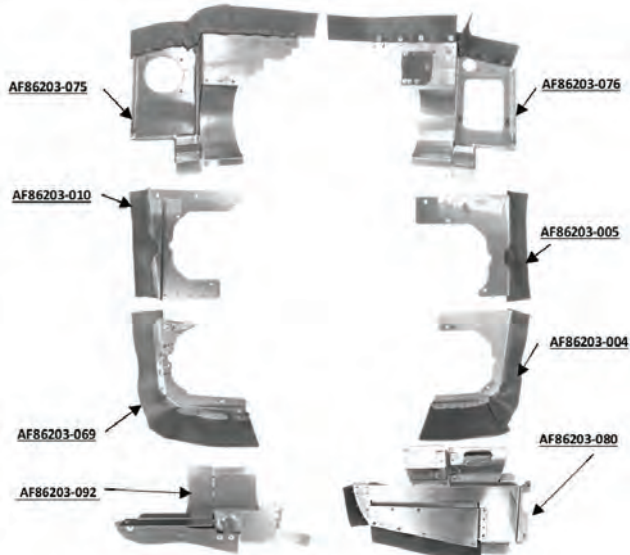

See eligibility on page 219

**Parts for Cessna 208 and 208B Aircraft  
See Caravan section on pages 229-236.**



**Save \$\$ on these in stock items!**