

FAA-PMA Approved

Airforms Complete FAA-PMA Product Line

Airforms is located in the heart of the Alaskan aviation scene. Their products are developed from real world needs of experienced Alaskan bush pilots and operators. All Airforms parts are manufactured using state-of-the-art CAD/CAM technology and CNC equipment combined with exemplary craftsmanship to provide the highest quality product.

**Stock in the lower
48 states for fast,
economical delivery!!**

Alaska Bush Tough!

**Nose Baggage Compartment Cargo Door
Up Latch for Cessna 207 Aircraft**
No more holding up the door while loading!
P/N AF1213922-1



- Improved strength
- Nickel plated for corrosion resistance
- Precision fit - drop in direct replacement
- Approved for all 207 models

Axles for Cessna Aircraft
Don't lose an airplane because of
a broken aluminum axle!

Steel axle P/N AF1441003-1

- Weighs only 2.28 lbs
- Save hundreds of \$\$

Titanium axle P/N AF1441003-1T

- Reduces weight by 2 lbs per A/C vs. steel axles
- Will not rust - perfect for saltwater environments

**Now also in
Titanium!**



Steel axle
P/N AF1441003-1



Titanium axle
P/N AF1441003-1T

Model
170, 170A,B
180, 180A-H
182, 182A-S
T182, R182, TR182
185, 185A-E, A185E-F
206, U206, U206A-G and TU206A-G
P206, P206A-E, TP206A-E
206H, T206H
305A,B,C,D,E,F
All serial numbers of each model listed are approved.

Door Latch for Piper Navajo PA-31 Aircraft
Will not deform after extended use!
P/N AF472-004



- Precision wire EDM machined from solid stainless steel
- Precision fit - drop in direct replacement
- Improved wear resistance
- Approved for all PA-31-310, 325 and 350 models with and without extended cargo door.

High Strength Parts for Helio H-295 Courier Aircraft
Parts are manufactured from high strength material and machined from a single billet
Stronger than original welded assemblies!

Axle
P/N AF250-040-495

- Cad plated for increased durability
- Precision fit - drop in direct replacement
- Accommodates wheel-ski installation



Stabilator Bracket
Left Hand P/N AF391-022-401-2
Right Hand P/N AF391-022-401-3

- Cad plated and primed for increased durability
- Sold as a match-machined set
- Mounting holes match drill at installation to ensure exact fit

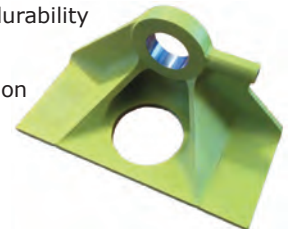

Complete Engine Baffle Kits

Keep your engine cool with new baffle kits!
Airforms is the premier manufacturer of FAA-PMA replacement baffle kits for Cessna, Piper and the Beechcraft Baron.

- 6061-T6 aluminum with black high temperature fiberglass reinforced silicone seals pre-installed (orange or blue seals available as special order for an extra charge)
- Bare aluminum or gray powder coat finish
- Individually interchangeable with factory baffles

Many Improvements:

- Stainless steel brackets where needed
- Hard rivet construction
- 1/2" back plates to secure seals
- Improved fit

Notes:

- If aftermarket components (starter, alternator, exhaust, engine mod, etc) have been installed it is the installer's responsibility to adjust baffles to fit.
- Mounting hardware is not included (nuts, bolts, screws, Tinnerman clips, etc).

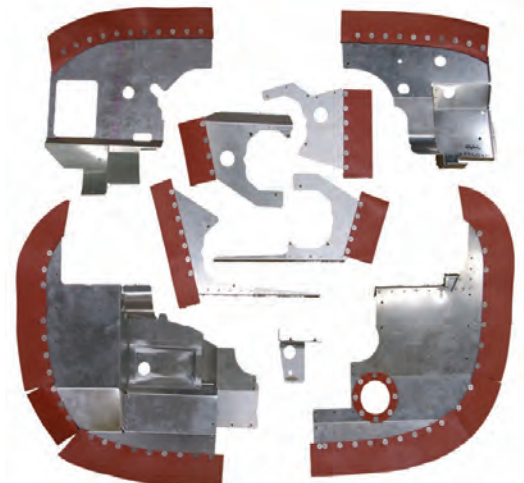

See eligibility and figures on the following pages



Eligibility for Airforms Engine Baffle Kits

Table with columns: Aircraft Model, Serial Number, Bare Aluminum P/N, Powder Coat P/N, Figure. Rows include manufacturers like Beechcraft, Cessna, Grumman, Mooney, and Piper with various model numbers and part numbers.

Notes:
1 Partial model eligibility
2 To determine the part number required see oil cooler configuration with applicable figure.
3 Baffle seals are available in black only.
4 P/N AF0550165-2 and AF0550165-6 are available in black only.
5 Baffle kits and components have received Alternative Method Of Compliance (AMOC) from the FAA for AD 93-23-13. Mandatory 50 hour inspection is no longer required.

See figures on the following pages

FAA-PMA Approved

Figure 1

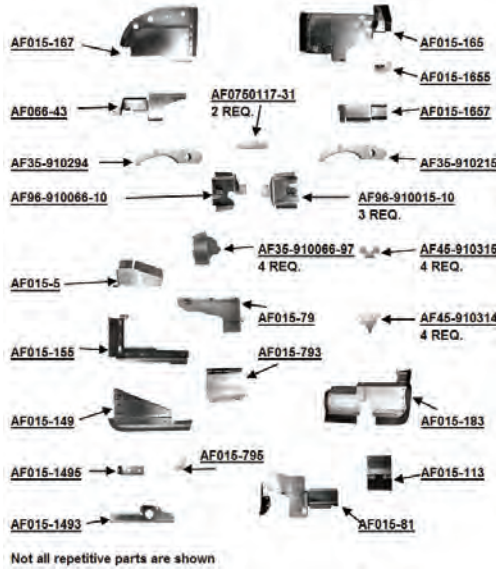

Figure 2

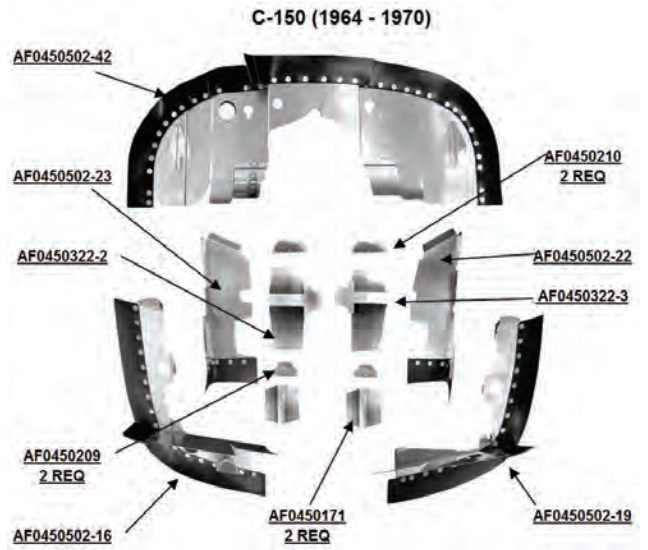

Figure 3

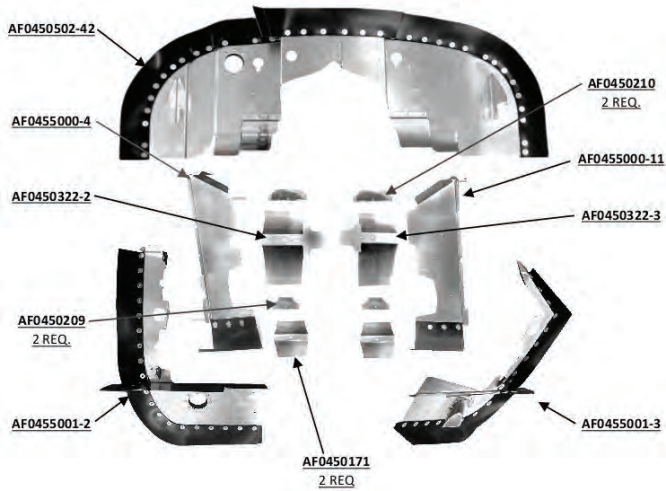

Figure 4

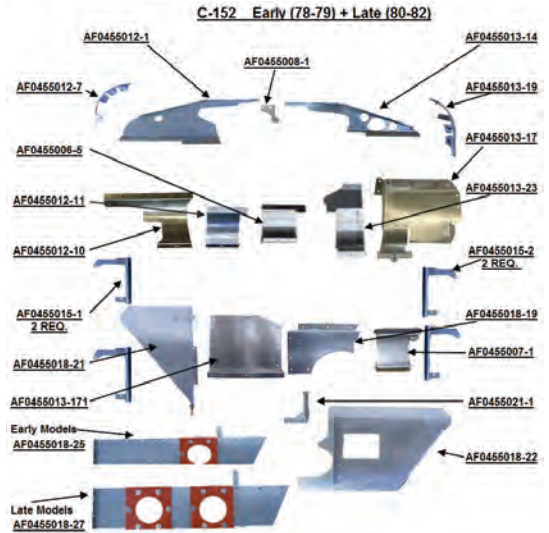

Figure 5

C-170A / B (49-55)

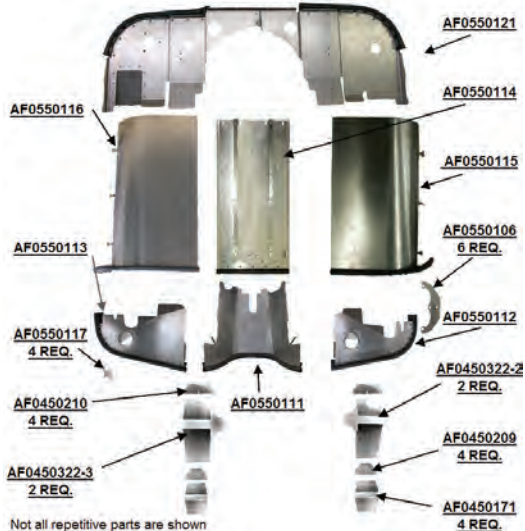

Figure 6

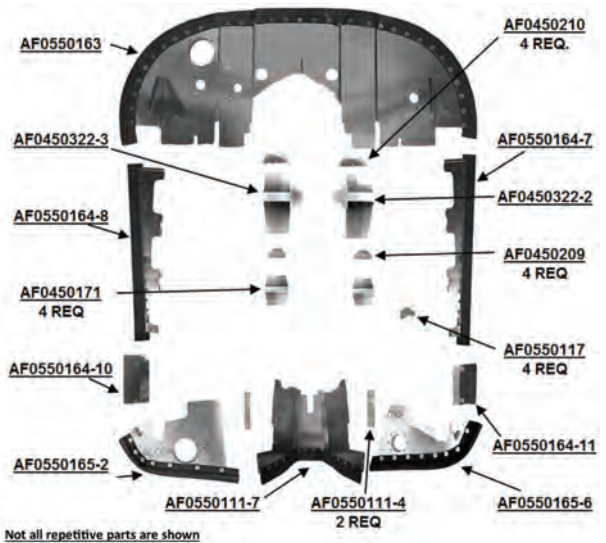

Figure 7

C-172IKLM

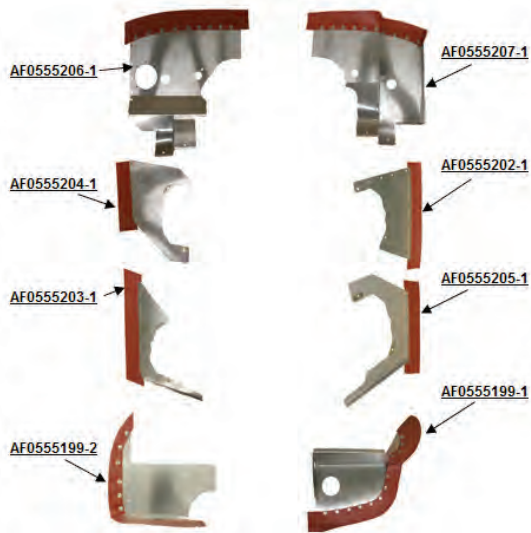

Figure 8

C-172M (1974-76)

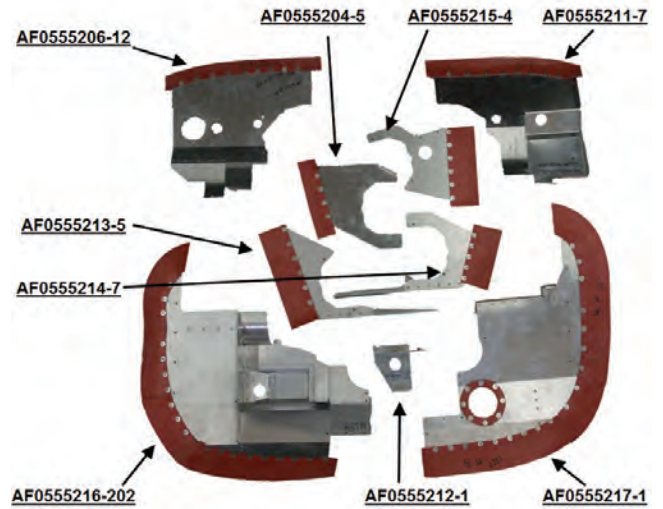

Figure 9

C-172N (77-79.5)

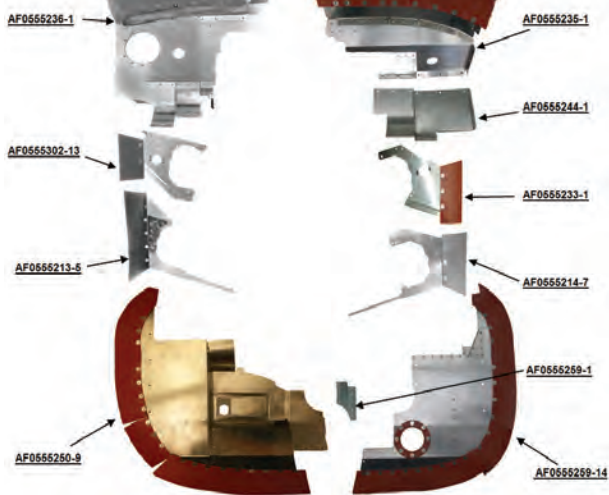

Figure 10

C-172N (79.5-80)

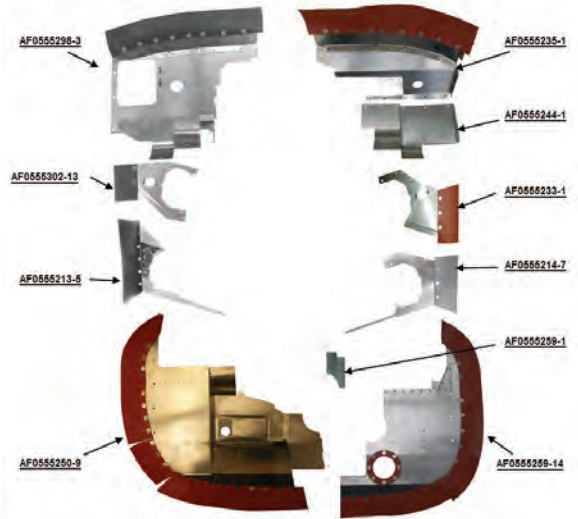

Figure 11

C-172P

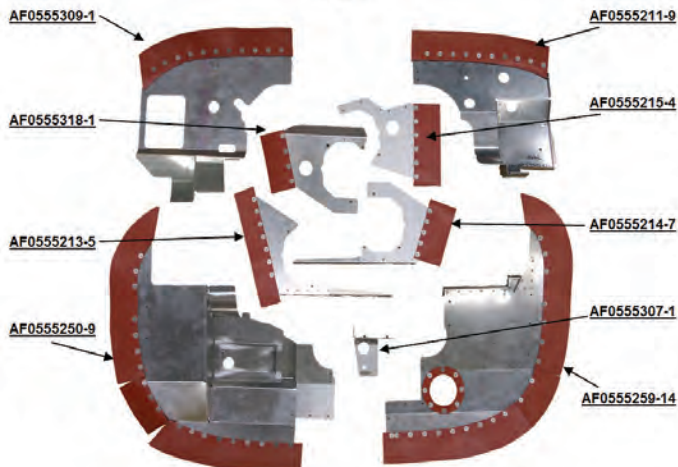

Figure 12

C-172 R (1997-98)

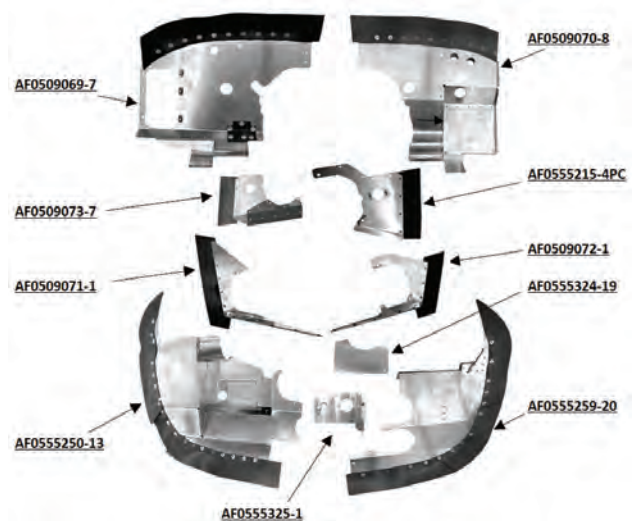

Figure 13

C-172 R (1999-04)

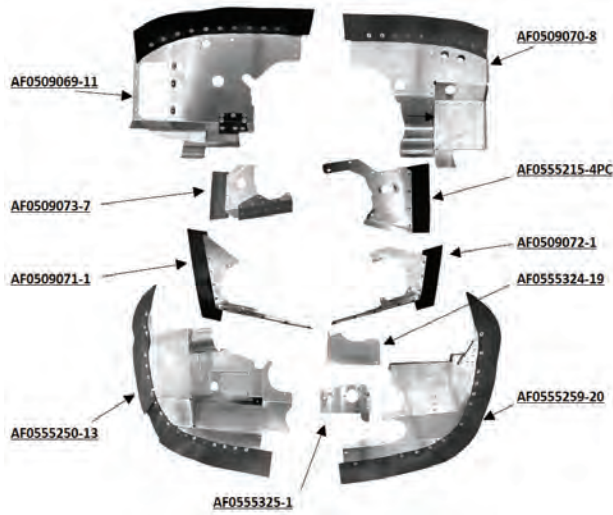

Figure 14

C-172 S

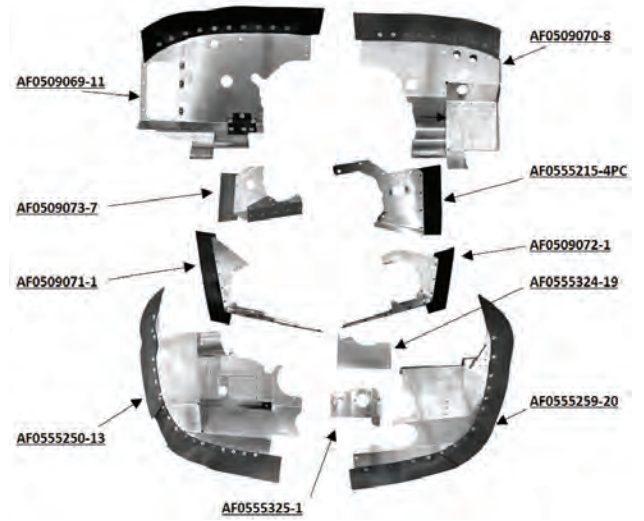

Figure 15

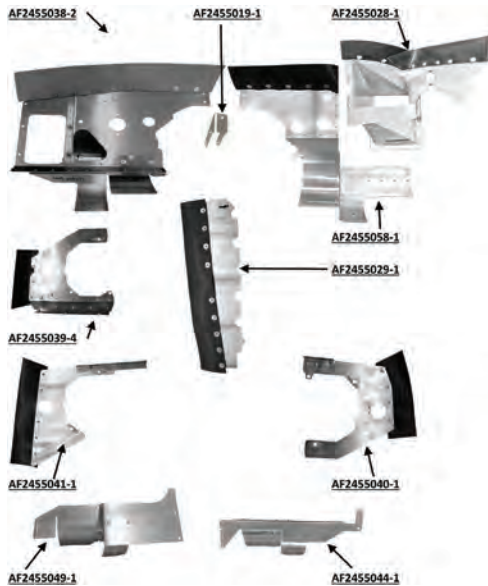

Figure 16

C-177 (68)

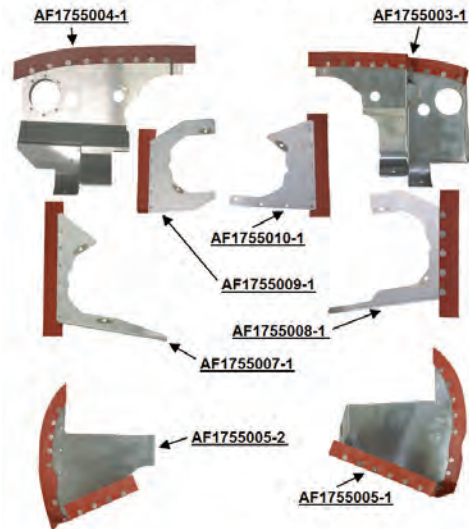

Figure 17

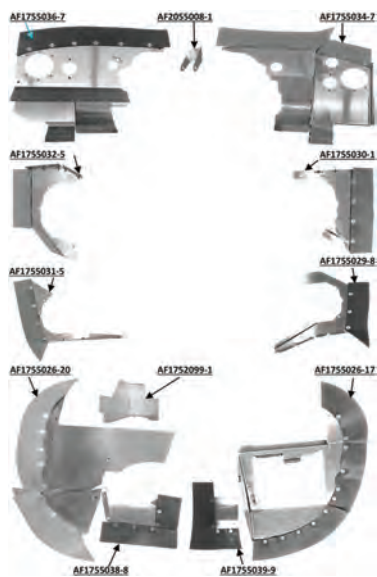

Figure 18

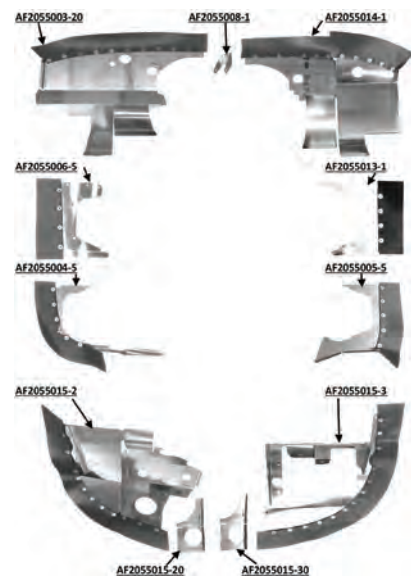

Figure 19

C-180 / 182 (58-73)

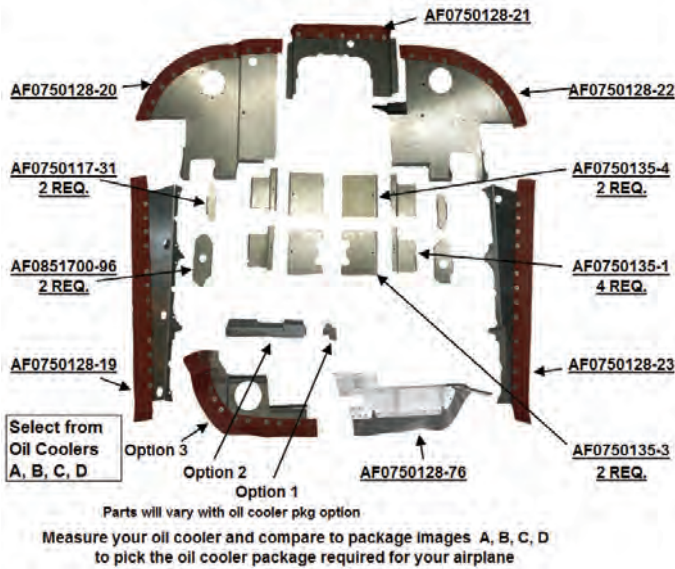
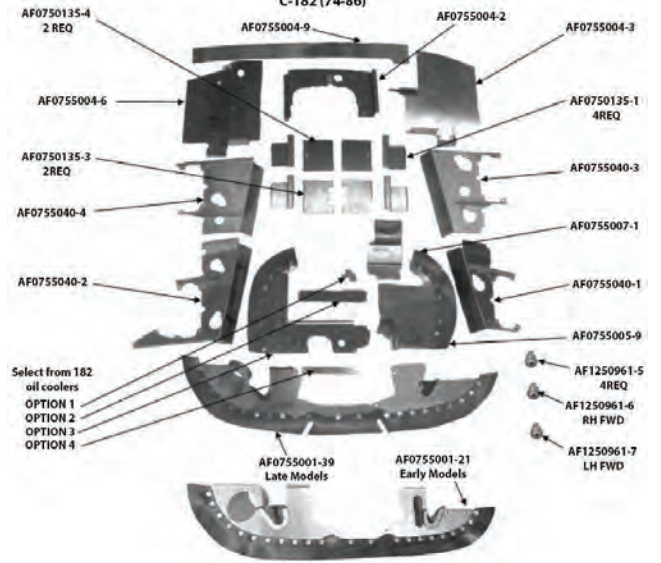
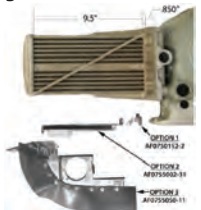

Figure 20

C-182 (74-86)



Package A



Package B



Package C

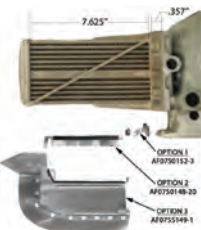

Package D

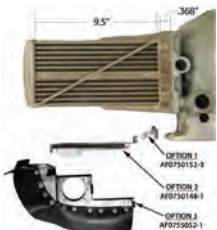

Package G

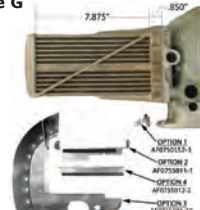

Package H

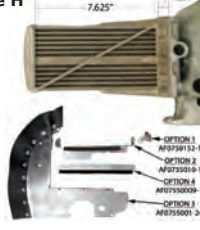
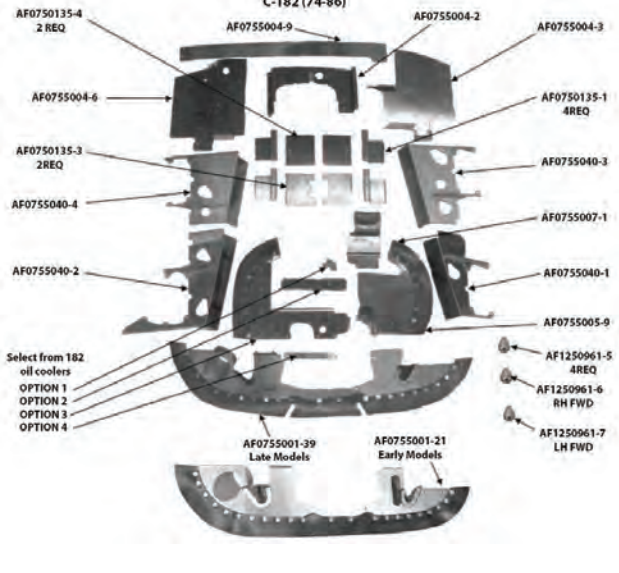
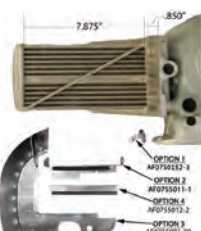

Figure 21

C-182 (74-86)



Package G



Package H

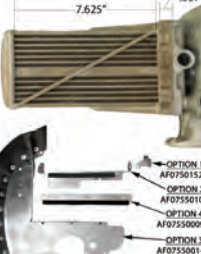

FAA-PMA Approved

Figure 22

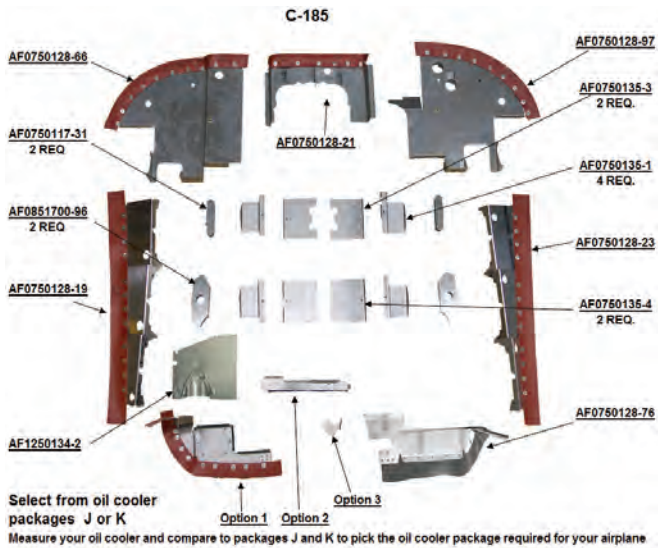

Package J

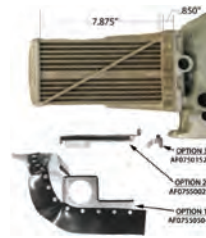

Package K

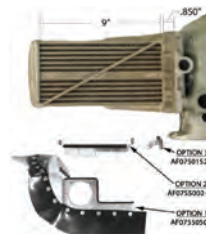
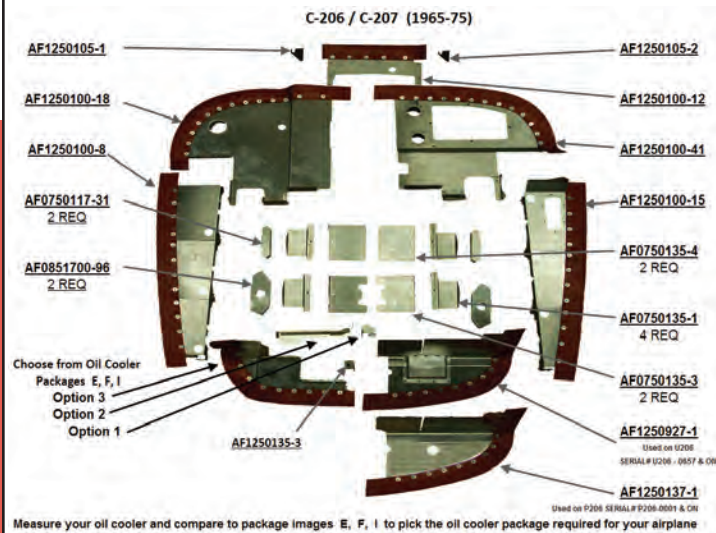

Figure 23



Package E



Package F

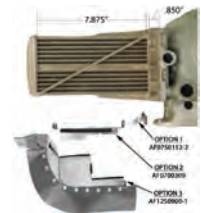

Package I

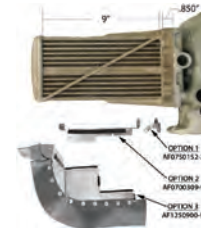

Figure 24

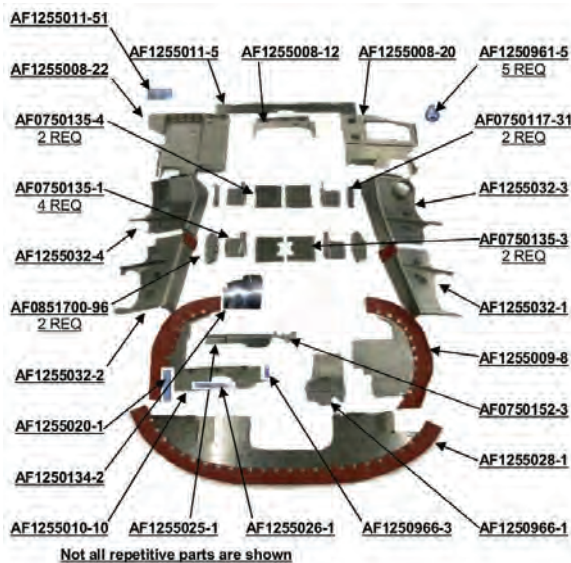
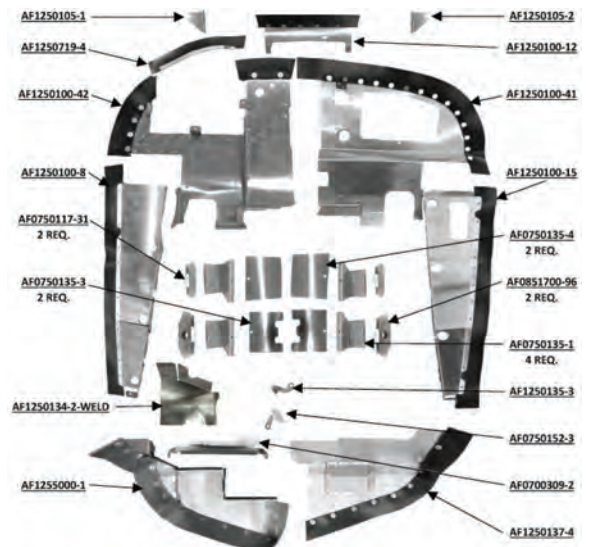

Figure 25



Parts manufactured by Airforms

Figure 26

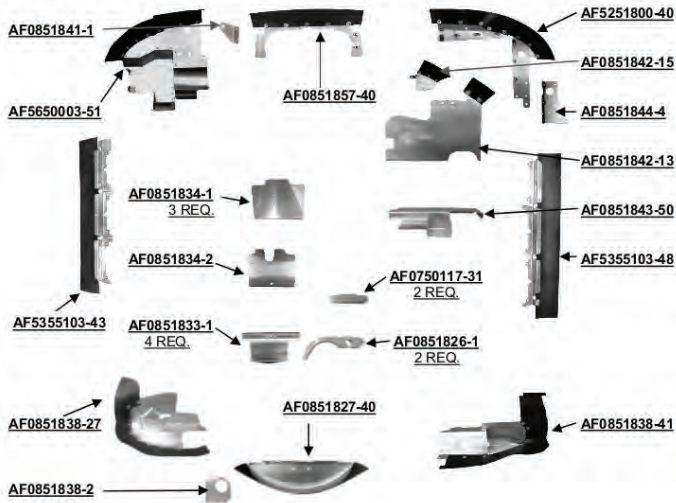

Figure 27

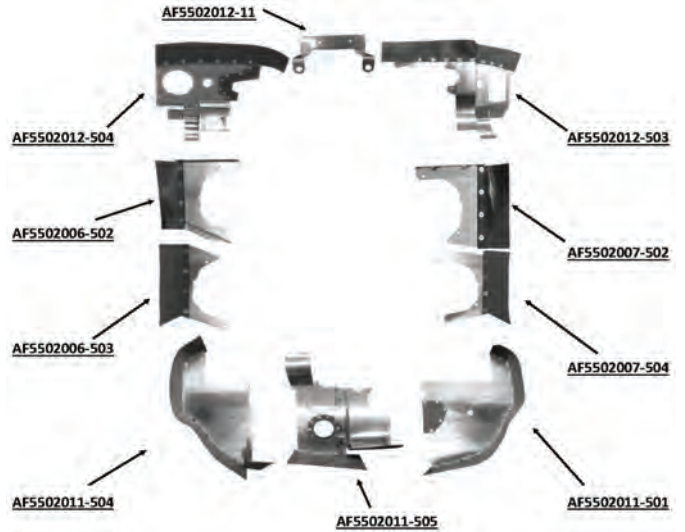

Figure 28

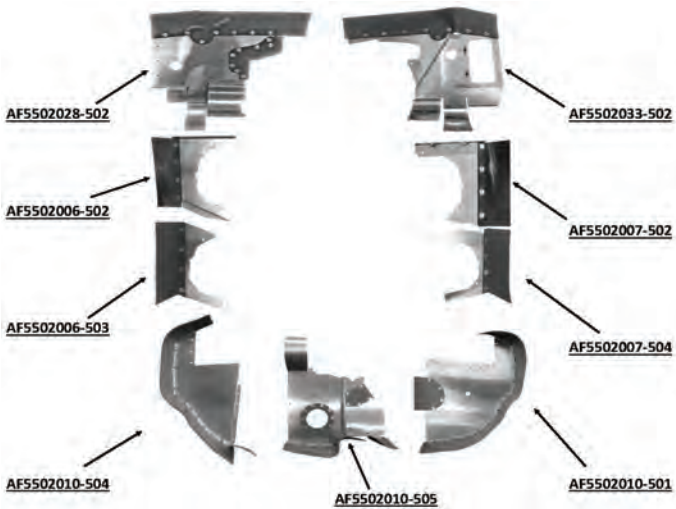

Figure 29

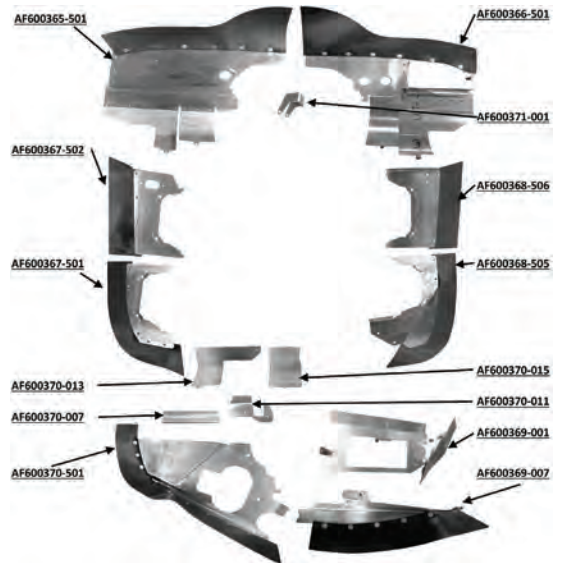

Figure 30

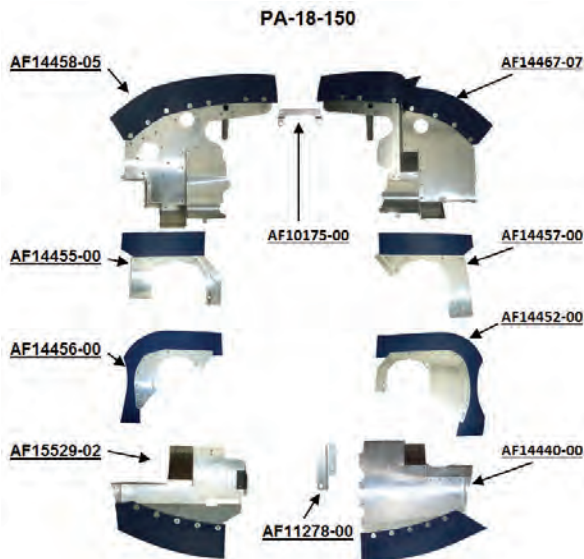

Figure 31

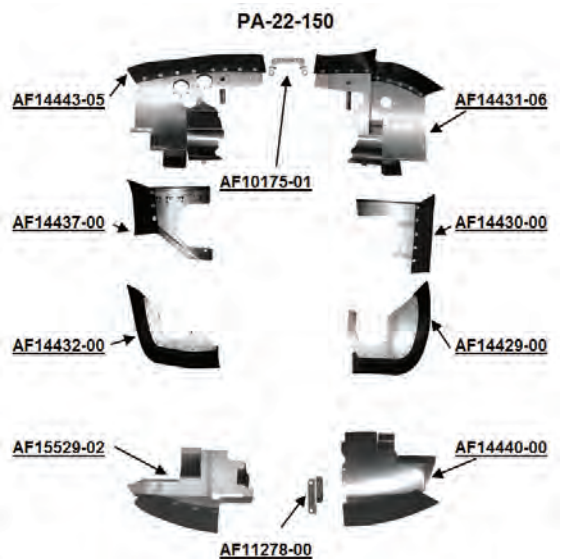

Figure 32

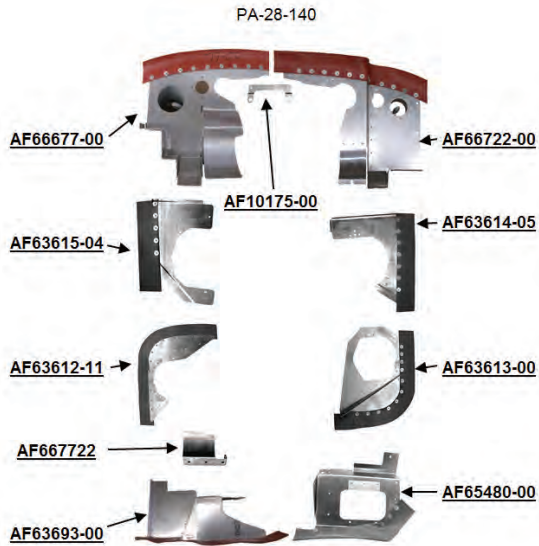

Figure 33

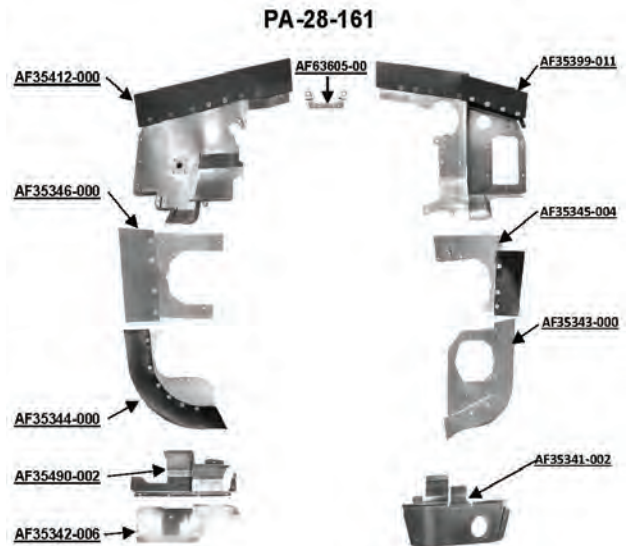

Figure 34

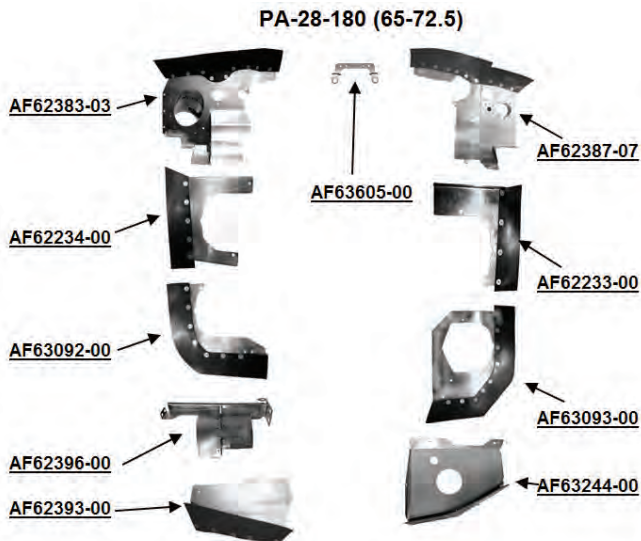

Figure 35

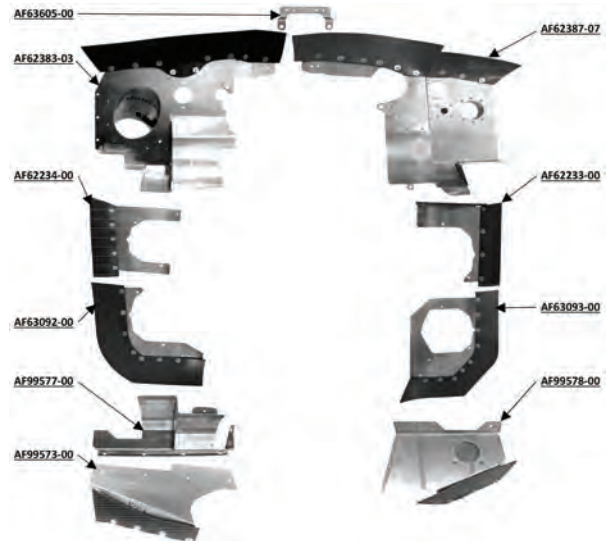

Figure 36

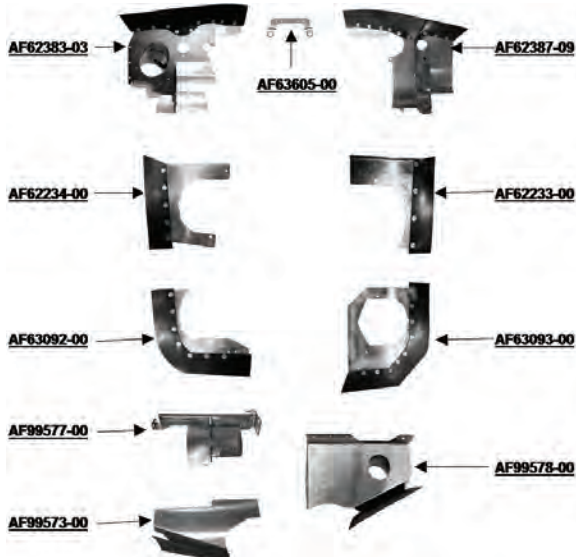

Figure 37

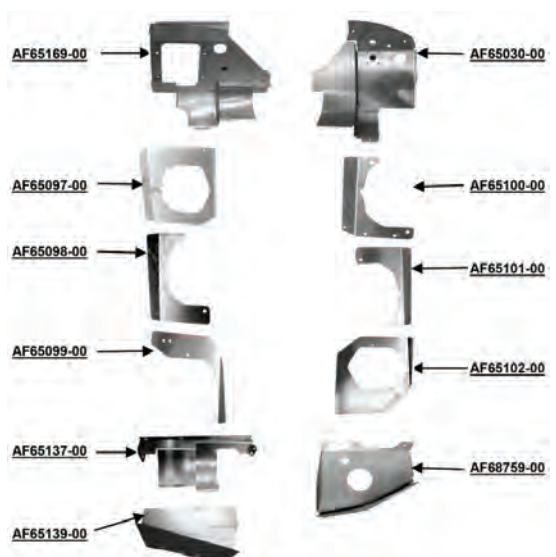

Figure 38

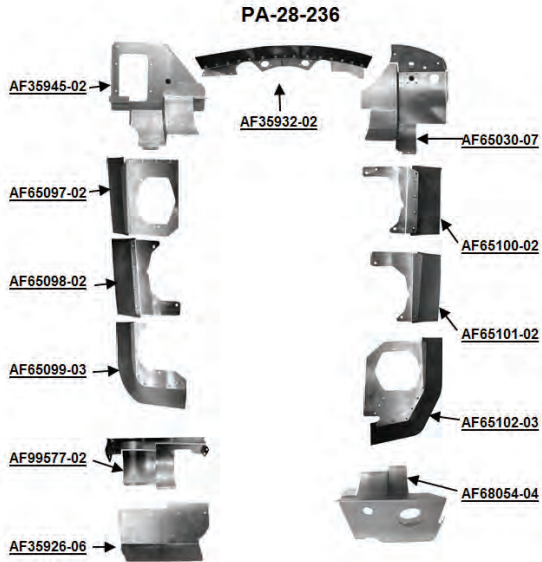

Figure 39

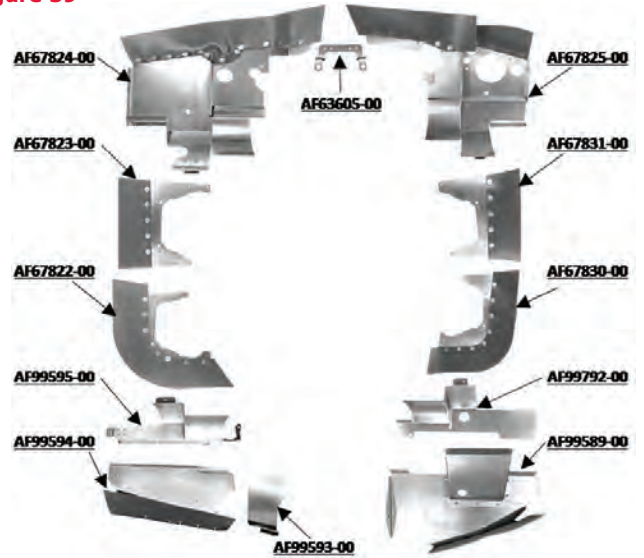

Figure 40

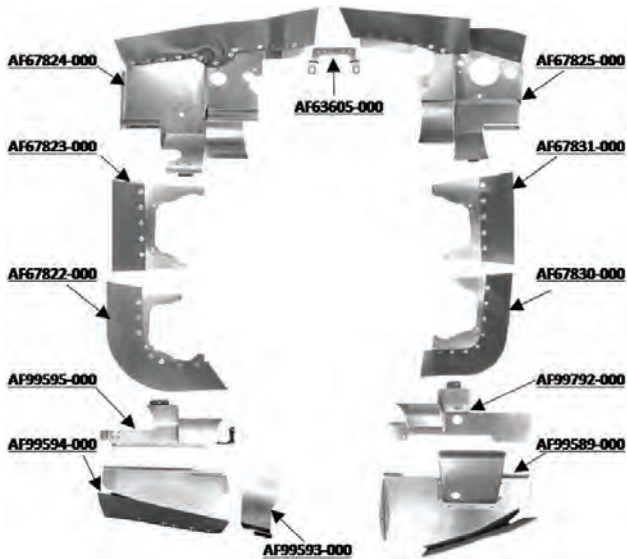

Figure 41

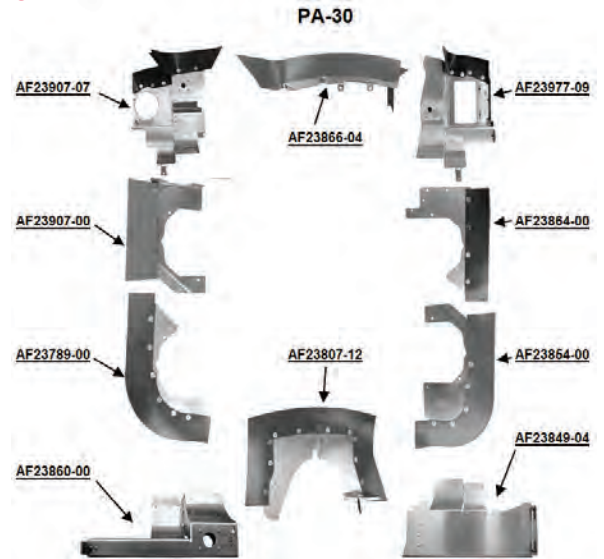

Figure 42

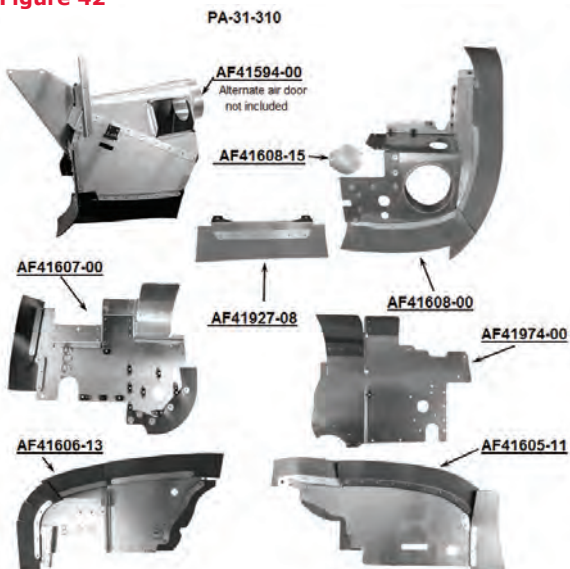
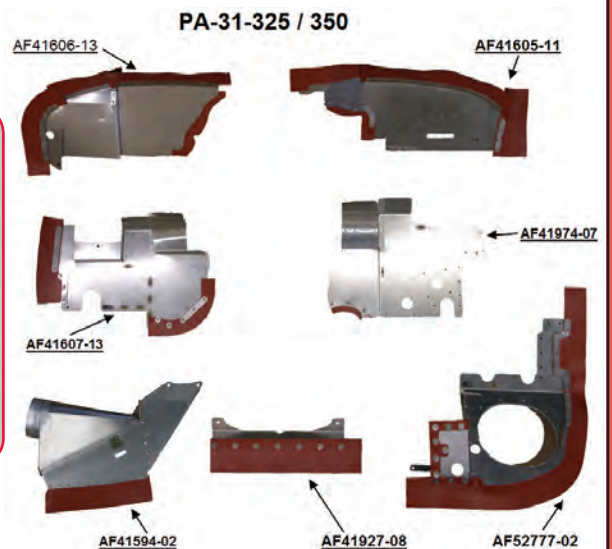

Figure 43



Baffle kits and components for models PA-31 (PA-31-310), PA-31-325 and PA-31-350 have received Alternative Method Of Compliance (AMOC) from the FAA for AD 93-23-13. Mandatory 50 hour inspection is no longer required.

Parts manufactured by Airforms

FAA-PMA Approved

Figure 44

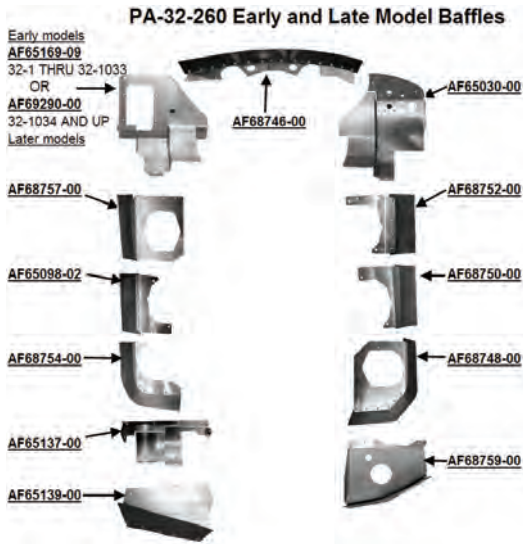

Figure 45

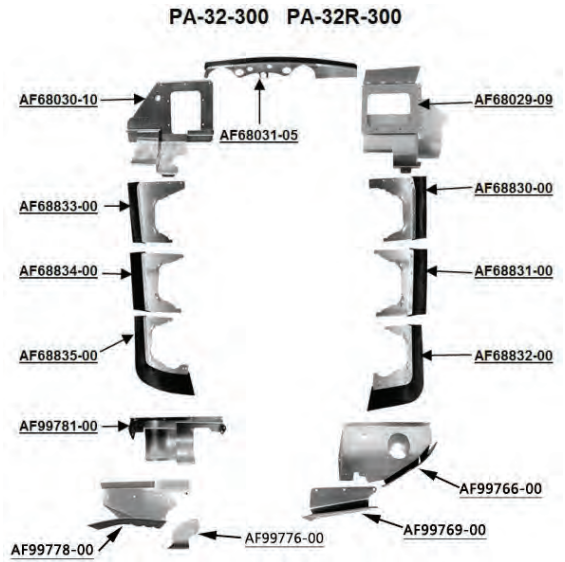
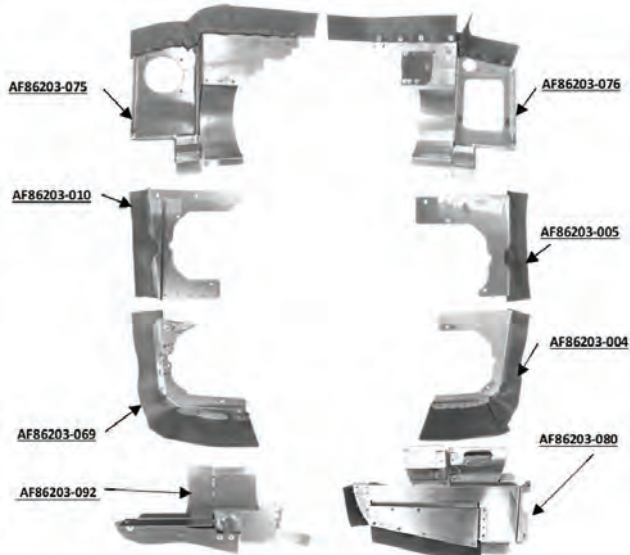

Figure 46



See eligibility on page 219

**Parts for Cessna 208 and 208B Aircraft
See Caravan section on pages 229-236.**



Save \$\$ on these in stock items!