



Create Your Go-Anywhere Adventure! Alaskan Bush Pilot Tested for over 50 Years!

Photo courtesy of F Atlee Dodge Aircraft Service

F Atlee Dodge Complete FAA-PMA Product Line

F. Atlee Dodge Aircraft Services is well known for high quality STC modifications and FAA-PMA products for Piper Super Cubs and Cessna aircraft. Their innovative designs are the result of over 50 years of experience keeping planes flying and productive in the rugged Alaskan wilderness.

- Make your airplane more rugged (*Alaskan Bush Tough!*)
- Improve safety
- Improve Horsepower
- Increase utility
- Decrease weight

Complete stock
in the lower 48 for
fast, economical
delivery!!

Carb Heat Box

Longer Life
P/N AD15005-00

PA-18 Series aircraft

- Self lubricating bearing for longer service life
- Manufactured from 304 stainless steel to prevent corrosion and rust.
- FAA-PMA



Weld on Float Fittings

Better than cheap copies
P/N 3143-12

PA-12, 12S, PA-14

P/N 3143-18

PA-18S-125, PA-18AS-125,
PA-18S-135, PA-18AS-135,
PA-18S-150, PA-18AS-150

Beefy, heavy construction, made from 4130 alloy steel.

- Used with Aerocet, Bauman, and EDO floats
- Sold in pairs - FAA-PMA/STC



Copied but never duplicated!

Air Filter Dome for PA18-150

Reinforced to go the distance
P/N 3281

- Reinforced with a doubler around the attach hole
- Powder coated white
- FAA-PMA approved



Two Piece Pre-Heat Shroud for PA-18

Makes exhaust inspection easy
P/N 3182

No need to remove the exhaust stack to remove the shroud.

- Clamps tight over the muffler
- FAA-PMA/STC approved



Heavy Duty Muffler for PA18

This muffler will last!
P/N 3241

- Heavier 321 stainless steel
- FAA-PMA/STC approved

Eliminates 50 hour inspections for AD68-05-01.

HOT-ROD Muffler for PA18

P/N 3241HR

More Horsepower, increased rate of climb and throttle response!

Lower oil and exhaust gas temperatures

- Larger chamber can and exhaust pipe for better gas flow
- No core or baffling inside to improve flow
- Larger inside diameter lets the engine breathe

Direct replacement FAA-PMA/STC approved

- New shroud, clamps and tailpipe clamp included
- Eliminates AD-68-05-01
- No modification to the cowling required
- Longer tailpipe keeps the airplane cleaner



*More
Horsepower!*

Muffler Shroud for PA-18

Don't fight the old lock bars!
P/N 3236

Quicker and easier to install than the original.

- Fits tight
- Two Piece
- FAA-PMA/STC approved





Make sure your Landing Gear can Take the Abuse!



Photo courtesy of Steve Pierce taken at Mile High Cliffs, Wrangell St. Elias National Park, Alaska

**Heavy Duty Main Landing Gear
2000 lb gross weight model**

PA-18 series and PA-19

Standard Height Gear

- 1-1/4" axle use P/N 3225-1 (LH) and 3225-2 (RH) **1**
- 1-1/2" axle use P/N 3225-1A (LH) **1** and 3225-2A (RH) **1**

3" Extended Height Gear

- 1-1/4" axle use P/N 3284-1 (LH) and 3284-2 (RH)
- 1-1/2" axle use P/N 3284-1A (LH) **1** and 3284-2A (RH) **1**

The 3" extended landing gear gives more height and prop clearance, which is especially important for sand or gravel landings.

FAA-PMA/STC approved.

Powder coat finish. Also available with Epoxy primer, Gloss White or "Wolf Hunter" Black for an additional charge.

Note:

Can be used on models J-3, PA-11, PA-12 and PA-14, but requires another STC modification involving additional parts and welding. Call for more information.

1 FAA Approval Pending



Safety Cables

Don't let a bungee failure cost you an airplane!

P/Ns 2089-12, 2089-18, 3344-12 **1** and 3344-18 **1**

- PA-12, PA-12S, PA-14 with Std Gear use P/N 2089-12
- PA-12, PA-12S, PA-14 with 3" Ext Gear use P/N 3344-12
- PA-18 and PA-19 series with Std Gear use P/N 2089-18
- PA-18 and PA-19 series with 3" Ext Gear use P/N 3344-18

Heavy 1/4" cable will get you home!

1 FAA Approval Pending



Main Gear Shock Struts

Heavy duty - but lightweight

P/Ns 3164-1, 3164-2, 3164-3 and 3164-4

- PA-12, PA-12S, PA-14, PA-18, PA-18-135, 150, PA-18-A135, A150
- PA-18 with std. landing gear use P/N 3164-1
- PA-12, PA-14 with std. landing gear use P/N 3164-2
- PA-18 with 3" ext. landing gear use P/N 3164-3
- PA-12, PA-14 with 3" ext. landing gear use P/N 3164-4

- For std landing gear or 3" ext. landing gear
- Sold individually, uses 2 per aircraft
- Powder coat finish. Also available with Epoxy primer, Gloss White or "Wolf Hunter" Black for an additional charge.



Cabane Vee

Alaska tough!

P/N 3166-1 and 3166-2

- PA-12, PA-12S, PA-14 use P/N 3166-2
- PA-18, PA-18-105, PA-18-125, PA-18-135, PA-18-A135, PA-18-150, PA-18-A150 use P/N 3166-1

- Beefed up in the right places
- Tough powder coat finish.
- Available in Gloss White for an additional charge
- 2 sizes - stock and 3" extended gear
- FAA-PMA/STC approved



Refueling Step

No more step ladders

P/Ns 3190/-10, 3190/-11, 3190/-12

- J3C-65, J3F-50, J3F-60, J3F-65, J-3L, J3L-65, J-4, J-4A, J-4B, J-5A, J5C, PA-11, 12, 14, 15, 16, PA18-105, 125, 135, A-135, 150, A-150, PA-19, PA-20, PA-20-115, PA-20-135, PA-22-108, 135, 150, 160

Clamps onto the main gear leg for easier refueling.

- Select part number by landing gear front tube OD: 1.25" OD use P/N 3190/-10
- 1.375" OD use P/N 3190/-11
- 1.5" OD use P/N 3190/-12
- Powder coated white, available in "Wolf Hunter" Black for an additional charge
- FAA-PMA/STC approved



Main Gear Long Step

Easy clamp-on modification

Much easier cabin entry

P/N 3195

- AE-1, HE-1, J3, J4, J5, PA11, PA12, PA14, PA18 and PA19 Series

The Main Landing Gear Long Step is usable on both sides of the aircraft as an entry step or refueling step. Heavy tube with 3 sizes of clamps.

- A must for bush gear and tires
- Alaska tested
- Durable non-skid surface stays on
- Powder coated white for durable corrosion resistance
- Available in "Wolf Hunter" Black at no additional charge
- FAA-PMA/STC approved



Silver Aircraft Ski Spring

Consistent tension regardless of temperature

P/N 2097

- J3, PA-11, PA-12, PA-14, PA-18, PA-19, PA-20, PA-22 Series

- Replaces ski bungee
- FAA-PMA/STC approved



Spar Reinforcing Strut Bracket

Spreads out lift strut spar loading

P/Ns 3192-12 and 3192-18

- PA-12, PA-14 series use P/N 3192-12
- PA-18, PA-19 series use P/N 3192-18

Protrudes out of the wing and attaches to the lift strut, preventing spar flex by reinforcing the front.

- Install during wing maintenance
- Powder coated white - stainless steel construction
- FAA-PMA/STC approved

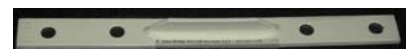



Extended Baggage Kit for PA-18 "150" Series

No welding required - Extends baggage area by almost 3 feet!
P/N 2103

- FAA-PMA/STC approved for most PA-18 aircraft
- Requires PA-18 "150" fuselage or equivalent previously approved 1750 lb gross weight modification at longitudinal station 99.0
- No welding required, may be assembled with blind or solid rivets
- Approximate compartment dimensions: 14" high X 15" wide X 35" deep
- Rated for 20 lbs of baggage

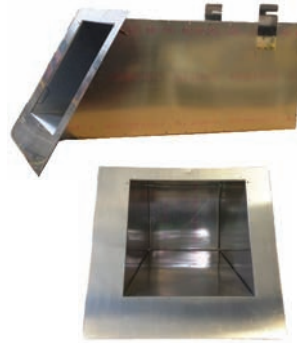
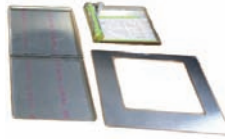
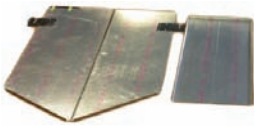

End view

'Weld-In' Extended Baggage Kit for PA-18 and PA-19 Series

Large volume for bulky, light-weight cargo!
P/N F1400-06 (FAA Approval Pending)

- STC approved for PA-18 and PA-19 aircraft
- Weld-In modification consisting of steel support frame and support tabs
- Great for storing wing covers, engine blankets, sleeping bags, paragliding sails and more
- Approximate dimensions: 22-1/2" wide at the front X 17-1/2" wide at the back X 43-1/2" deep
- 10 lb maximum load

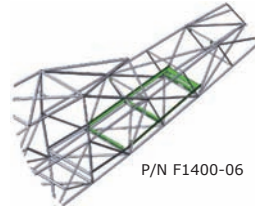

P/N F1400-06

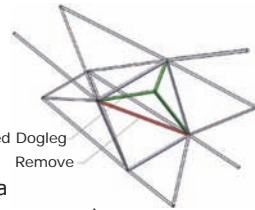

Inverted Dogleg Remove

Inverted Dogleg STC for PA-11, PA-12, PA-18 and PA-19 Series

Makes loading baggage easier! STC SA02436AK

- Relocates the diagonal tube to the upper right corner
- FAA/STC approved for PA-11, PA-12, PA-18 and PA-19 aircraft
- Allows easy access to the aft baggage area from the baggage door
- No more catching your gear when removing it from the extended baggage area
- Longer cargo can be placed at an angle for easier insert/removal through the baggage door

Safari Seat for PA-18, PA-19 Series

P/N 6151

Easily installed and removed
Clamps in and designed for easy removal with quick release pins.

Weight saver

Lightweight folding rear seat saves 10 pounds over existing seat.

FAA-PMA/STC



Saves 10 Pounds!

Under Seat Battery Rack for PA-18, PA-19 Series

Easy battery removal
P/N 3304

Mounts under front seat for easy removal and warm-up of battery.

- Uses FAA-PMA Battery P/N 0769-4005
- FAA-PMA/STC approved



Saves 15 Pounds!

Lightweight Dry Battery - 680 Amps

Superior vibration resistance
P/N 0769-4005

- Big power in a little box
- Leak proof, high G rated
- 12 year design life and 6 to 10 year service life
- Required with under seat battery rack P/N 3304
- FAA-PMA



Saves 15 Pounds!

Rear Seat Heater for PA18 Series

A must for winter flying - Alaska proven!
P/N 3175

- Heater modification using warm exhaust heat to heat back seat
- Requires some modification to the firewall
- Log book entry only - no FAA 337 form required
- Complete with firewall valve and control
- FAA-PMA/STC approved



Folding Front Seat and Seat Kit for PA-18, PA-19 Series

Makes entry and loading much easier!
P/N 3186 Folding Seat Kit

FAA-PMA/STC



Aircraft Tie-Down Brackets for PA-12, PA-18 Series

Prevents failure at the lift strut attach point
P/N 3197

Designed to take the load off the attach point.

- Sold individually
- Uses 2 per aircraft
- FAA-PMA/STC approved



Removable Rear Seat Crossbar

Makes loading easy
P/N 3146-1

- PA-18-105, 125, 135, 150, PA-18S-105, 125, 135, 150, PA-19S, PA-19

- FAA-PMA/STC approved
- Installation instructions, pins, and blocks included



Cargo Tie Down

Secure your cargo
FAA-PMA

P/N TDP-31

- Piper PA31, PA31-300, PA31-325, PA31-350, PA31P, PA31P-350, PA31-T, PA31-T1, PA31-T2 and PA31-T3 series

Clamps to seat rails to provide tie down points to secure cargo.

- 4 req. for every 100 lbs of cargo
- Anodized aluminum for durability
- FAA-PMA/STC approved

Note: This product is not to be used as a seat stop.



Pilot Seat Belt Attachment Kit

Weld on front seat belt attach kit!
P/N 3246

- PA11, PA11S and PA18 series aircraft

- Relocates seat belts to floorboard
- Secures pilot to fuselage in the event of an accident.





Husky Main Landing Gear
Heavy Duty!
P/Ns AD45017-501HD and AD45017-502HD

- A-1, A1A and A1B series Aviat Husky aircraft
- 1.3 lbs. heavier per side
- Used primarily on aircraft equipped with skis
- Replaces P/Ns 45017-501 and 45017-502

Firewall, Stainless Steel and Titanium
P/N 8007-01 for Stainless Steel
P/N 8007-02 for Titanium

- PA18 series aircraft, PA19 and PA19S
- Replaces P/Ns 12365-003, 12365-005, 12365-007 and 12365-009
- Titanium is 2.8 lbs lighter than stainless steel

Strobe Light Mounting Bracket for PA-18, PA-19 Series
P/N 2087
For use with small Whelan strobe lights
FAA-PMA/STC

Header Tank
Direct replacement for original sheet metal tank
Front P/N 3169-1A
Rear P/N 3169-2

- PA-18, 18-105, 125, 135, 150, A-150, PA-19
- Heavy-duty welded aluminum
- Light weight
- Eliminates cracking
- FAA-PMA/STC approved

Vented Fuel Cap
Easy removal - No more corrosion
P/N 3267

- PA-11, PA-11S, PA-12, PA-12S, PA-14, PA-18 and PA-19 Series
- Vertical fin on top for easy removal.
- Gasket is included for Avgas
- Eliminates A.D.
- FAA-PMA/STC approved

Aluminum Oil Cooler for PA18, PA22 Series
Save weight and money!
P/N 8000328

- The only aluminum Super Cub oil cooler
- FAA-PMA

Save 3.7 lbs!

Brake Reinforcing Channel for PA-18 Series
No more cracking!
P/N 4231

- Made with 4130 steel for durability
- Located underneath the brake system and the front seat. The brake pedal is attached to the brake channel.
- FAA-PMA approved

Upper and Lower Cowl Channel for PA-18 Series
No More Rust or Vibration
Upper P/N 3276
Lower P/N 3277

- Stainless steel - Eliminates rust and vibration failure
- No pre-drilled holes, allowing for a precise fit.
- Sold individually - 2 upper and 2 lower required per aircraft
- FAA-PMA

Front and Rear Shoulder Harness Attach Bracket
Make your Cub safer!
Front Bracket P/N 3232-1
Rear Bracket P/N 3232-2
FAA-PMA

- J-3C, 3F, 3L, J-5A,5B, 5C, PA-11, PA-11S, PA-12, PA-12S, PA-18 Series

Oversize Rudders and Elevators
Increased control authority!
P/N AD15726OS (rudder)
P/N AD12770OS (elevator)

- PA-12, PA-12S, PA-14, PA-18 Series, PA-19S
- Approximately 12% larger
- Powder coated grey with bushings installed
- FAA-PMA/STC approved

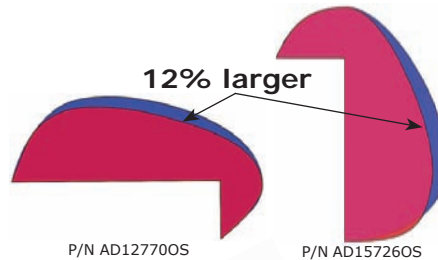

**Parts Manufactured by
F Atlee Dodge for Cessna Aircraft**

Landing Gear Box Shims
P/N AD0441023-2
.100" tapered shim
P/N AD0441023-160
.160" tapered shim
P/N AD0741022-1
.040" shim
P/N AD0741022-2
.050" shim

- For Cessna aircraft using leaf spring landing gear
- 4130N steel, plated
- FAA-PMA

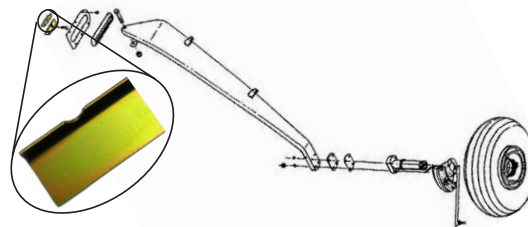

Save\$\$

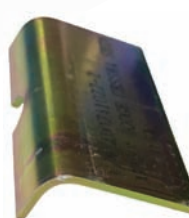
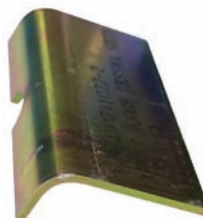

Model	Qty per Aircraft			
	AD0441023-2	AD0741022-1	AD0741022-2	AD0441023-160
120, 140, 140A		A/R		
150A	2-4	A/R		
150B, C, D, E, F, G, H, J, K	2-4	A/R		2
A150K				2
A150L, F150F, G, H, J	2-4	A/R		
F150K, FA150K	2-4	A/R		2
170, 170A, B		A/R		
180, 180A, B, C, D, E		A/R		
180F	2-4	A/R		
180G, H, J, K	2-4	A/R		A/R
180J, K	2-4	A/R	A/R	A/R
185, 185A, B, C, D, E, A185E	2-4	A/R		A/R
A185F	2-4	A/R	A/R	A/R
190, 195A, B		A/R		
A/R = use as required				



Photos courtesy of Henry Brown, Bob & Ruthie Warner and Dave Hayden, members of the International 180-185 Club

Cargo Tie Down

Secure your cargo
TDC-208

FAA-PMA/STC approved

Caravan 208, 208A, 208B

Clamps to Cessna seat rails to provide tie down points to secure cargo.

- 4 required for every 100 lbs of cargo
- Anodized aluminum for durability

Note: This product is not to be used as a seat stop.



V-Brace

Stainless Steel
P/Ns 180VBE and
AD1242001-18

FAA-PMA

180, 180A, 180B use P/N 180VBE
206, U206, T206A-G, U206A-G and
207, T207 use P/N AD1242001-18



Boot Cowl Handle

Slightly larger to accommodate gloves!
P/N 3354H

180H,J, A185E,F, U206/TU206A,B,C,D,E,F,G, P206/TP206A

- Undrilled
- May not match up with existing bolt pattern due to alternate styles used by OEM.
- Replacement for P/N 0713191-1
- FAA-PMA

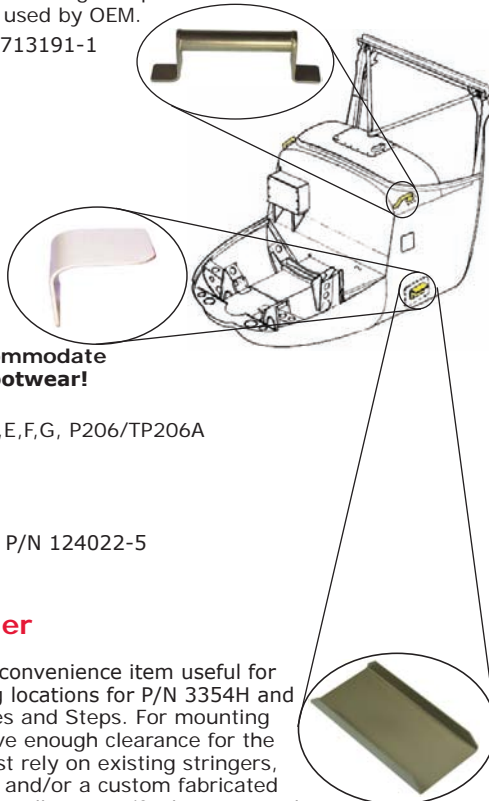

Boot Cowl Step

Slightly larger to accommodate
hunting and fishing footwear!
P/N 3354S

U206/TU206A,B,C,D,E,F,G, P206/TP206A

- Undrilled
- White powder coating
- 2 per aircraft
- Direct replacement for P/N 124022-5
- FAA-PMA

Boot Cowl Doubler

P/N 3354D

Doubler P/N 3354D is a convenience item useful for reinforcing the mounting locations for P/N 3354H and 3354S Boot Cowl Handles and Steps. For mounting locations that do not have enough clearance for the doubler the installer must rely on existing stringers, other existing structure, and/or a custom fabricated doubler. It is up to the installer to verify the structural integrity of the attachment.

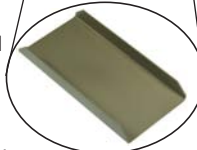

Tailpipes

Heavier duty and longer to keep exhaust
away from airplane!

FAA-PMA



AD1250256-7 AD1250264-6
AD1242013-1 AD1242013-2
AD1254004-3 AD1254004-4

Aircraft Model	AD1242013-1 LH Seaplane	AD1242013-2 RH Seaplane	AD1250256-7 LH Landplane	AD1250264-6 RH Landplane	AD1254004-3 LH Assembly	AD1254004-4 RH Assembly
210-5 (205), 210-5A (205A)			•	•		
206, U206, U206A,B,C,D,E,F,G	•	•	•	•		
P206, P206A			•	•		
P206B,C,D,E			•	•		
207, 207A, T207, T207A					•	•
210C,D,E,F,G,H,J,K,L,M,N,R			•	•		

Rudder Pedal Bar

Avoid risk of costly damage
during assembly
P/Ns AD1260558-1 (LH) and
AD1260558-2 (RH)

Each bar includes 2 ea. P/N S1003-43A bearings and 1 ea. P/N 1260419-1 tube pre-assembled. This avoids damage commonly caused while pressing the bearings during installation.



P/N AD1260558-1

P/N AD1260558-2

FAA-PMA

Aircraft Model

210-5 (205), 210-5A (205A)	•	•
206, U206G, TU206G	•	•
206H, T206H	•	•
207A, T207A	•	•
210M,N,R, T210M,N,R, P210	•	•

Rudder Pedal Shaft

P/N AD0411778-2
FAA-PMA

1/2 of Cessna Price!



Aircraft Model

140A	
150, 150A, F150, FA150	
152, A152, F152, FA152	
170, 170A,B	
172, 172A,B,C,D,E,F,G,H,I,J,K,L,M,N,P	
F172D,E,F,G,H,I,J,K,L,M,N,P	
172RG, P172, R172E,F,G,H,K, FP172, FR172	
175, 175A,B	
180, 180A,B,C,D,E,F,G,H,J,K	
182, 182A,B,C,D,E,F,G,H,I,J,K,L,M,N, 182P,Q,R	
A182, F182, FR182, R182, TR182	
185, 185A,B,C,D,E, A185E,F	
190, 190A, 195, 195A,B	
210-5 (205), 210-5A (205A)	
206, U206, U206A,B,C,D,E	
P206, P206A,B,C,D,E	
207, T207	
210, 210A,B,C,D,E,F,G,H,J,K, T210G,H,J	



Folding Rear Seats

Convert from people to cargo in just a few minutes!
P/N 3187 (includes the left and right seats)

170 thru 170B, 172 thru 172S, 175 thru 175C,
180 thru 180K, 182 thru 182D

P/N 3187-182E (includes the left and right seats)

FAA Approval Pending

182E thru 182T, 185 thru A185F

The FAA-PMA/STC approved folding rear seats replace the existing bench seat and increase the flexibility and utility of your airplane. The seats can be independently folded forward, stowed to the side, or totally removed in minutes to allow cargo and passenger configurations.

- Easy access to baggage
- Easier access to the tail cone for maintenance
- Increased payload! About 20 pounds lighter than the original bench seat



**20 Pounds
Lighter!**

Frees wasted space

The original bulky bench seats take nearly twice as much floor space as the compact, yet comfortable folding seats.

- 50% more baggage space
- More leg room

Convenient installation kit

Seats are sold in pairs (left and right) as a kit with all required installation hardware, including mounting tracks that attach to the floor and side door frame. (Seat belts, upholstery, cushioning, and stowage straps/bungees not included).

Upholster to match your interior

This is not a "jump seat" or "utility seat". You don't have to sacrifice comfort and style. Seats provide room for a cushion and upholstery up to 2 inches thick. Match your interior for an attractive and comfortable finish.



Firewall Mounted Battery Rack

Easier access and less weight!
P/N 8008-01

Quick and easy mounting

The Firewall Mounted Battery Rack mounts on the firewall on existing stringers or channels, allowing for quick and easy mounting and easier servicing with no extra support required.

Shorter wiring

With shorter wiring, power loss from long wires is eliminated and starting is improved.

- Better C.G.
- Designed for the Lightweight Dry Cell Battery, P/N 0769-4005
- FAA-PMA/STC approved

Model
150K, A150L, F150K, FA150K
170, 170A,B
172B,C,D,E,F,G,H,I,K,L,M,N,P
F172D,E,F,G,H,K,L,M,N,P
R172E,F,G,H,J,K
175, 175A,B,C
180, 180A,B,C,D,E,F,G,H,J,K
182, 182A,B,C,D,E,F,G,H
185, 185A,B,C,D,E, A185E,F

**Saves 19
Pounds!**



Lightweight Dry Battery - 680 Amps

Superior vibration resistance P/N 0769-4005

- Big power in a little box. leak proof, high G rated
- FAA-PMA approved for PA18 and PA19 series when STC SA02138AK is installed
- 12 year design life and 6 to 10 year service life
- Fits battery rack P/N 8008-01
- FAA-PMA



Saves 15 Pounds!

Heavy Duty Muffler Shroud, LH

Stainless steel shroud for longer life
P/N AD1250250-6

- 206 and 207 Series aircraft
- Direct replacement for OEM shroud
- FAA-PMA



Heavy Duty Muffler Shroud

No more cracking or vibration damage!
P/N 4236

- 180 and 185 Series Aircraft
- Only one pound heavier
- Tailpipe outlet doubler spot welded on
- FAA-PMA



Heavy Duty Tailpipe Clamp

Heavier material and cheaper!
P/N AD1250259-1

- 206 and 207 Series aircraft
- Extra doublers to prevent cracking of the attach mounts
- FAA-PMA



Heavy Duty Seat Back Frame

Heavy Duty - 10 oz. heavier with less tendency to wear out!
P/N 3226

206 Series aircraft
Replaces P/N 1214012-1 and 1214012-4



Tailpipe Hanger Assembly

Longer service life for less \$\$
P/N AD1250255-7

U206E,F,G, 210K,L,M,N,R

Mounting bracket and hanger tab are fabricated from thicker material to ensure longer service life.

- Manufactured with 304 Stainless Steel (except for strap)
- 2 per aircraft
- FAA-PMA



Exhaust Deflector Assembly

Deflects noise and exhaust gasses away from the aircraft!
P/N 3238

206, U206, P206, P206B-E, U206A-G

- FAA-PMA/STC approved



Tailpipe Support Assembly

Heavy Duty!

Mounting bracket and hanger tab are fabricated from thicker material to ensure longer service life.

- Manufactured with 304 Stainless Steel (except for strap)
- FAA-PMA

Model	P/N	Qty per Aircraft
210-5, 210-5A (205, 205A)	AD1250258-1	4
206, U206A,B,C,D,E, P206A,B,C,D,E	AD1250258-1	4
207, 207A, T207, T207A	AD1254003-1 (LH)	2
	AD1254003-2 (RH)	2
210B,C,D,E,F,G,H,J,K, T210F	AD1250258-1	4



P/N AD1250258-1



P/N AD1254003-1



P/N AD1254003-2

Landing Gear Axle Shim

Tapered shim to adjust axle alignment
P/N AD1941007-1

207, 207A, T207, T207A

- 2 per aircraft
- FAA-PMA
- Save \$\$\$

1/3 of Cessna Price!

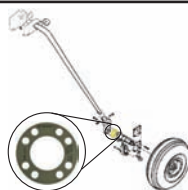

Parts manufactured by F Atlee Dodge



Breather Tube

Replace worn breather tubes with cost effective replacements!
P/Ns AD1200106-108 (Fwd)
AD1200106-166 (Aft), AD0700147-9 (Aft)

- Direct replacement at less than half the cost
- FAA-PMA



(Fwd) P/N AD1200106-108

Maintenance Tip:
Support breather tubes directly to the engine, not the cowl or airframe, to prolong breather tube life.

(Aft)
P/N AD1200106-166

Model	P/N
180F,G,H,J,K	AD1200106-108 (Fwd)
182H,J,K,L,M,N,P,Q,R	AD1200106-108 (Fwd)
185, 185A,B,C	AD1200106-108 (Fwd)
182D,E, A185E,F	AD1200106-108 (Fwd) AD0700147-9 (Aft)
188, 188A,B, A188, A188A,B	AD1200106-108 (Fwd)
U206, U206A,B,C,D,E,F,G	AD1200106-108 (Fwd)
TU206A,B,C,D,E,F,G	AD1200106-108 (Fwd)
P206, P206A,B,C,D,E	AD1200106-108 (Fwd)
TP206A,B,C,D,E	AD1200106-108 (Fwd)
207, 207A, T207, T207A	AD1200106-108 (Fwd) AD1200106-166 (Aft)
210D,E,F,G,H,J,K,L,M,N,R	AD1200106-108 (Fwd)
T210F,G,H,J,N	AD1200106-108 (Fwd)

Horizontal Stabilizer Spacer

P/N AD0732101-7

- Used at the horizontal stabilizer aft attach bracket/hinge
- Check spacer when servicing stabilizer jack screws

Model
180A,B,C,D,E,F,G,H,J
182, 182A,B,C,D
185, 185A,B,C,D,E, A185E,F
A188B, T188C
210-5 (205), 210-5A (205A)
210, 210A,B,C



Engine Mount

Heat Shield
Stainless steel for longer service life
P/N AD1250918-2

- 4 per aircraft
- FAA-PMA



Save!

Aircraft Model
U206A,B,C,D,E,F,G, P206A,B,C,D,E
TU206A,B,C,D,E,F, TP206A,B,C,D,E
207, 207A, T207, T207A
210K,L,M,N,R, P210N, T210G,H,J,K,L,M,N,R

Exhaust Shroud

P/N AD1250251-17

- Durable, high quality construction!
- Made from thicker steel to remedy cracking around attach holes.



Model
210-5 (205), 210-5A (205A)
206, U206, U206A,B,C,D,E,F
P206, P206A,B,C,D,E

Engine Mount

Bonding Strap
P/N AD0750137

- 4 per aircraft
- FAA-PMA



1/3 of Cessna Price!

Aircraft Model
180, 180A,B,C,D,E,F,G,H,J,K
182, 182A,B,C,D,E,F,G,H,J,K,L,M,N,P, 182O,R, T182
185, 185A,B,C,D,E, A185E,F
188, 188A,B, A188, A188A
210-5 (205), 210-5A (205A)
210, 210A,B,C,D,E,F,G,H,J,K,L,M,N,R
P210N,R, T210F,G,H,J,K,L,M,N,R

Shaft, Trim Wheel

Huge Savings!
P/N AD0761205-9

- 180H,J,K, 185D,E, A185E,F
- Save nearly 80%
- Better roll pin engagement - Enlarged or mangled roll pin holes create a safety issue
- FAA-PMA



Nosegear Drag Link

Durable, High Quality Construction!
P/N AD1243600-1

- Corrosion resistant white powder coated finish
- Alaskan Bush Tough!
- Save more than 50%!
- FAA-PMA

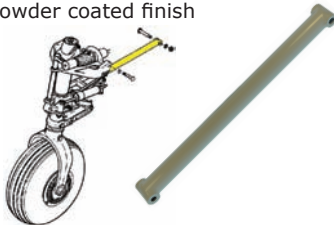

Model
U206B,C,D,E,F,G
TU206B,C,D,E,F,G
P206B,C,D,E
TP206B,C,D,E
207, 207A, T207, T207A

V Brace Assembly

Durable, High Quality Construction!

- P/Ns AD0513003-19, AD0713103-2
- Thicker baseplate and feet to prevent cracking
- Annealed stainless steel legs
- Save almost \$3,000!
- Longer service life
- FAA-PMA

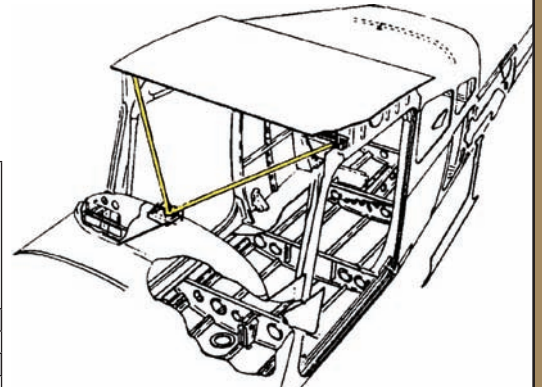

Model	AD0513003-196	AD0713103-2
180, 180A,B,C,D,E,F,G	•	•
180H,J,K	•	•
185, 185A,B,C	•	•
A185E,F	•	•

Rudder Pedal Shaft

P/N AD1460501-21



Model
150A,B,C,D,E,F,G,H,J,K,L,M
A150K,L,M, F150K,L,M
172D,E,F,G,H,K,L,M,N,P, 172RG
F172D,E,F,G,H,K,L,M,N,P
FP172, FR172E,F,G,H,J,K, P172D,R172K
177, 177A,B
180F,G,H,J,K
182E,F,G,H,J,K,L,M,N,P,Q,R
F182P,Q, FR182, R182, T182, TR182
185B,C,D,E, A185E,F
188, 188A,B, A188, A188A,B, T188C
210-5 (205), 210-5A (205A)
U206F,G
207, 207A, T207, T207A
210C,D,E,G,H,J,K,L,M,N, T210K,L,M,N
336
337, 337A,B,C,D,E,F,G,H, F337E,F,G,H, FT337E, F337GP, T337B,C,D,E,F,G,H

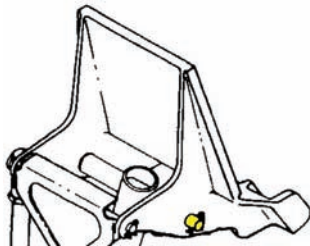

Alternator Adjust Arm

P/N AD0750221-1

- Direct replacement
- 1/4 of the cost compared to OEM
- FAA-PMA

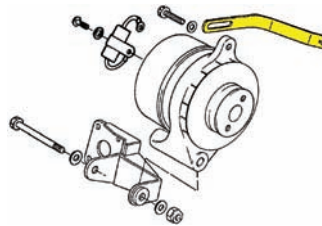

Model
180F,G,H,J,K
182O,R, F182O
185, 185A,B,C,D,E, A185E,F
206, U206, P206

Entry Step

Stronger & corrosion resistant
P/N 8013-01

- 170 thru 170B,
- 180 thru 180F
- 185 thru 185E

The FAA-PMA approved cabin entry seats are made with a reinforced corner, making them stronger than the original. Powder coated white for corrosion resistance.

- Left and right step are universal
- FAA-PMA/STC approved

