

Cowl Saver™ Baffle Seal Material

Reduce airframe vibration, stop cowl and firewall cracks

You can feel the difference in the cockpit!

Now also available with Bi-Flex™ technology!

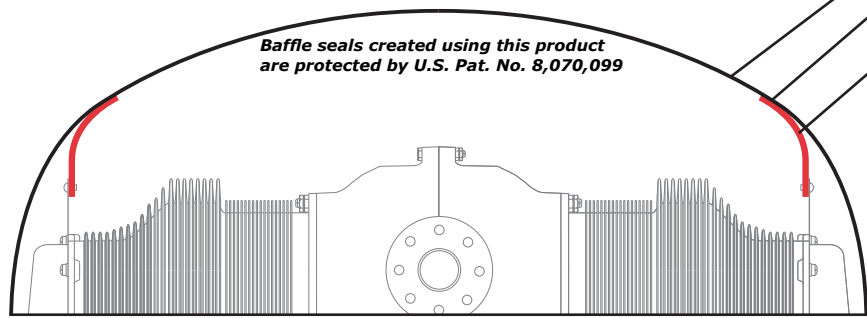

Baffle Seal Friction Causes Airframe Vibration and Destroys Cowls

Typical silicone rubber baffle seals have a coefficient of friction among the highest of any known material. This friction transfers engine vibration into your cowl and firewall causing fastener fretting, fatigue, cracking, chaffing and airframe vibration.

Cowl Saver™ Baffle Seal Material has 30 Times Less Friction!

- One side is silicone and the other is a low friction Teflon surface unique to the patented **Cowl Saver™** baffle seal material.
- **Cowl Saver™** dramatically reduces the friction between your cowl and baffle seals.
- Half of the engine vibration you feel in the cockpit is from baffle seal transfer.

Low Friction Saves You Money!

- Reduces transfer of vibration to the engine cowl and airframe
- Minimizes cowl chaffing and erosion from baffle seals
- Extends baffle seal life
- Reduces expensive cowl and cowl fastener repairs
- Reduces fatigue and cracking in baffles, cowl skins and firewall
- The cowling even goes on easier!

Unbeatable Performance

- Ideal balance of flexibility and stiffness
- Fiberglass reinforced
- Meets industry standard AMS3320G
- McFarlane quality you can count on!

Bi-Flex™ Technology

The three inch rolls of Cowl Saver™ material are now also available with a precision laser engraved flex pattern to ensure an optimum flexibility/stiffness combination for maximum cooling and minimum friction. The flex pattern covers a little less than half of the width of the material. See next page for more details.



Convenient Baffle Seal Repair Kits

Kit P/N BAFFLE-KIT-1		
Qty	P/N	Description
1	CS085X3X108G	3 in X 108 in (9ft) Cowl Saver™
1	RIVET-KIT-2	Baffle Seal Rivet Kit
10	6036-012	Baffle Seal Retainer Strips
<i>Best for small aircraft with straight baffle seals</i>		
Kit P/N BAFFLE-KIT-1BF with Bi-Flex™		
1	CS085X3X108GBF	3 in X 108 in (9ft) Cowl Saver™ with Bi-Flex™
1	RIVET-KIT-2	Baffle Seal Rivet Kit
10	6036-012	Baffle Seal Retainer Strips
<i>Best for small aircraft with straight baffle seals</i>		
Kit P/N BAFFLE-KIT-2		
1	CS085X18X36G	18 in X 36 in (3ft) Cowl Saver™
2	RIVET-KIT-2	Baffle Seal Rivet Kit
20	6036-012	Baffle Seal Retainer Strips
<i>Recommended for most aircraft. Allows fabrication of straight, curved or irregular shaped baffle seals.</i>		
Kit P/N BAFFLE-KIT-3		
1	CS085X3X156G	3 in X 156 in (13ft) Cowl Saver™
1	RIVET-KIT-2	Baffle Seal Rivet Kit
14	6036-012	Baffle Seal Retainer Strips
<i>Best for aircraft with straight baffle seals</i>		
Kit P/N BAFFLE-KIT-3BF with Bi-Flex™		
1	CS085X3X156GBF	3 in X 156 in (13ft) Cowl Saver™ with Bi-Flex™
1	RIVET-KIT-2	Baffle Seal Rivet Kit
14	6036-012	Baffle Seal Retainer Strips
<i>Best for aircraft with straight baffle seals</i>		

Cowl Saver™ Baffle Seal Material

Part Number	Thickness	Size
CS085X3G	.085 in	3 in wide, sold by the foot
CS085X18X36G	.085 in	18 in X 36 in (3 ft)
CS085X36X36G	.085 in	36 in X 36 in (3 ft)
CS085X3X108G	.085 in	3 in X 108 in (9 ft)
CS085X3X108GBF	.085 in	3 in X 108 in (9 ft) with Bi-Flex™
CS085X3X156G	.085 in	3 in X 156 in (13 ft)
CS085X3X156GBF	.085 in	3 in X 156 in (13 ft) with Bi-Flex™

Color: Black/Gray

Baffle Seal Retainer Strip

Part Number 6036-012

Use as a retainer for riveting baffle seals to baffles

- .050 inch thick 6061-T6 aluminum
- Corrosion resistant
- Economical
- 7/16" X 12" strips - cut to length during installation
- Clamps better than washers or light gauge sheet metal

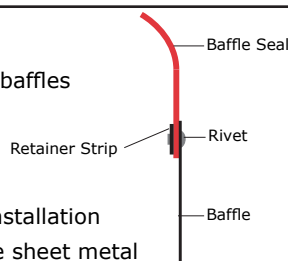

Baffle Seal Rivet Kit

Part Number RIVET-KIT-2

- Soft rivets that won't deform baffles
- Several sizes for various baffle thicknesses and hole sizes

RIVET-KIT-2	
Qty	Rivet P/N
100	MS20470A3-5
100	MS20470A4-5
100	MS20470A4-6

Rivets included are approximate



McFarlane Aviation Products

696 East 1700 Road
Baldwin City, Kansas 66006
sales@mcfarlaneaviation.com



www.mcfarlaneaviation.com

800.544.8594
785.594.2741
Fax 785.594.3922

Customizable Flexibility for Optimal Cooling

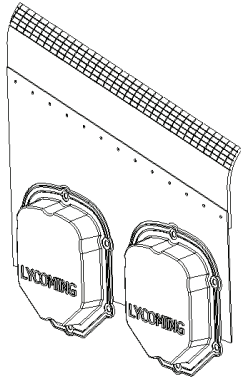

Cowl Saver™ engine baffle seal material can be customized to be extremely flexible for a perfect seal where it contacts the cowl and rigid elsewhere to prevent the seal from blowing past the cowl contact line. With other baffle seal materials, you must compromise

and make a choice: either use material that is rigid enough to not blow past the cowl contact line, or use a material that is flexible enough to blend to the intricate contours of the engine cowl to ensure a good seal. Either choice results in less than optimal engine cooling. With Cowl Saver™ baffle seal material you no longer have to compromise.

Flexibility can be customized to only the areas of the baffle seal that you want it.

Cowl Saver™ material has a layer of black Teflon (clear for older material) bonded to a flexible reinforced silicone rubber base. In addition to low friction, the Teflon also gives the laminate the solid stiffness needed near the engine baffle to prevent the seal from blowing past the cowl contact line. This extra stiffness, however, is not always desirable in the area that the material seals against the contours of the cowl.

Where extra flexibility is needed to make a good air seal, the black Teflon layer can simply be scored in a cross hatch, diagonal or parallel line pattern.

With care, a normal razor blade may be used, or McFarlane **P/N TOOL120** may be used for more efficiency and greater control of cutting depth. Alternatively for relatively straight sections, three inch wide rolls of Cowl Saver™ material with **Bi-Flex™** technology may be used.

For Bi-Flex™ Material with a precision laser engraved flex pattern, see next page.



3 inch roll with Bi-Flex™ P/N CS085X3X108GBF

The extreme bond of the Teflon layer is not affected by the scoring. The score line spacing and the extent of the score pattern control the amount of flexibility. The score line orientation and the type of pattern control the direction(s) of flexibility. Score patterns as small as 1/8 inch form little islands of friction free Teflon that has shown good durability while providing the extreme flexibility of soft silicone rubber. This customization can be performed when doing a new baffle seal installation or to perfect the fit and seal of an existing installation. As long as care is taken to just score the Teflon layer and as little of the silicone as possible (do not cut the fiberglass reinforcing layer), the material will still meet the original AMS3306 specification to which it was certified.

Cowl Saver™ Scoring Tool

Customize Your Baffle Seal Flexibility for Optimal Cooling!
P/N TOOL120



Only for use on the Teflon side of Cowl Saver™ baffle seal material

Customize Cowl Saver™ engine baffle seal material to be extremely flexible for a perfect seal where it contacts the cowl and rigid elsewhere to prevent the seal from blowing past the cowl contact line.

This unique tool has 3 circular razor blades spaced 0.16" apart and makes it fast and easy to score the stiffer outer layer of the Cowl Saver™ material where more flexibility is required. The spacers also precisely control the depth of the cuts to help prevent damage to the material.

- You control the amount of flexibility.
- Use on a new baffle seal installation or to perfect the fit and seal of an existing installation.
- Material still meets the original AMS3306 specification to which it was certified as long as the fiberglass reinforcing layer has not been cut.
- Replacement blade kit also available (P/N TOOL120-BKT)



Baffle Seals and Cowl Saver™ Kits for Cessna 172Q, R and S Models

Reduce airframe vibration and stop cowl and firewall cracks with a complete Cowl Saver™ kit!

U.S. Patent No. 8,070,099

- Cut to fit. Saves time.
- Low friction for reduced transfer of engine vibration
- Kit includes all required baffle seals, MS20470A4-5 soft rivets, and McFarlane P/N 6036-012 retainer strips.
- Individual baffle seals also available

Now with Bi-Flex™ Technology!

Precision laser engraved flex pattern ensures optimum flexibility/stiffness combination for maximum cooling and minimum friction.



FAA-PMA Approved!

Save!

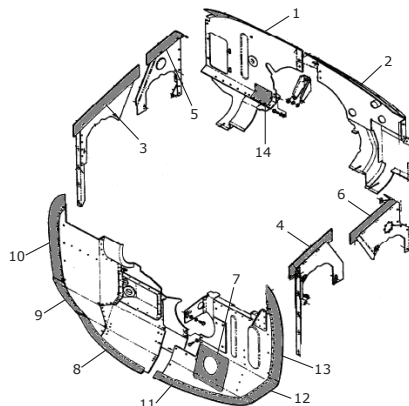

Part Number	Idx	Aircraft	Location
BSC-KT-1		172R, S	Baffle Seal Kit
MC0509069-4	1	172R, S	RT AFT
MC0509070-4	2	172Q,R,S	LT AFT
MC0509071-2	3	172Q,R,S	CYL 1 RT FWD
MC0509072-4	4	172Q,R,S	CYL 2 LT FWD
MC0509073-6	5	172R,S	CYL 3 RT AFT
MC0509074-2	6	172Q,R,S	CYL 4 LT AFT
MC0509079-2	7	172R,S	AIR INTAKE FOR HEAT MUFF
MC055250-17	8	172R,S	FWD RT LWR
MC055250-18	9	172R,S	FWD RT MID
MC055250-19	10	172R,S	FWD RT UPR
MC055259-25	11	172R,S	FWD LT LWR
MC055259-26	12	172R,S	FWD LT MID
MC055259-27	13	172R,S	FWD LT UPR
MC2455076-1	14	172R,S	RT AFT SUB PANEL

McFarlane Aviation Products
696 East 1700 Road
Baldwin City, Kansas 66006
sales@mcfarlaneaviation.com

McFarlane

©2015 McFarlane Aviation, Inc. All rights reserved.

www.mcfarlaneaviation.com
800.544.8594
785.594.2741
Fax 785.594.3922